

Landcal Blackbody Source

Type P1200B

User Guide

Land Instruments International
Dronfield S18 1DJ
England
Telephone: (01246) 417691
Facsimile: (01246) 410585
Email: land.enquiry@ametek.com
Internet: www.ametek-land.com

AMETEK Land, Inc.
150 Freeport Road.
Pittsburgh, PA 15238. U.S.A.
Telephone: (412) 826 4444
Facsimile: (412) 826 4460
Email: irsales@ametek.com
Internet: www.ametek-land.com



SAFETY WARNING

Insulation made from High Temperature Insulation Wool Refractory Ceramic Fibre, (better described as Alumino Silicate Wool) (ASW)

This product contains alumino silicate wool products in its thermal insulation. These materials may be in the form of blanket or felt, formed board or shapes, mineral wool slab or loose fill wool. Whilst there is no evidence of any long term health hazards, we strongly recommend that safety precautions are taken whenever the materials are handled.

Exposure to fibrous dust may cause respiratory disease.

When handling the material always use an approved respiratory protection equipment (RPE-i.e. FFP3), eye protection, gloves and long sleeved clothing.

Avoid breaking up waste material. Dispose of waste in sealed containers.

After handling, rinse exposed skin with water before washing gently with soap (not detergent). Wash work clothing separately.

Before commencing any major repairs we recommend reference to the European Association representing the High Temperature Insulation Wool industry (www.ecjia.eu)

Health and Safety Information



Read all of the instructions in this booklet - including all the **WARNINGS** and **CAUTIONS** - before using this product. If there is any instruction which you do not understand, **DO NOT USE THE PRODUCT.**

Safety Signs



WARNING

Indicates a potentially hazardous situation which, if not avoided, could result in death or personal injury.



CAUTION

Indicates a potentially hazardous situation which, if not avoided, could result in minor or moderate injury to the user or users, or result in damage to the product or to property.

NOTE

Indicates a potentially hazardous situation which, if not avoided, could result in damage or the loss of data.

Signs and Symbols used on equipment and Documentation



Caution, risk of electric shock.



Caution, attention to possibility of risk of damage to the product, process or surroundings. Refer to instruction manual.



Caution, hot surface.



Protective Conductor Terminal.



Observe precautions for handling electrostatic discharge sensitive devices.

Equipment Operation

Use of this instrument in a manner not specified by Land Instruments International may be hazardous. Read **and understand** the user documentation supplied **before** installing and operating the equipment. The safety of any system incorporating this equipment is the responsibility of the assembler.

Protective Clothing, Face and Eye Protection

It is possible that this equipment is to be installed on, or near to, machinery or equipment operating at high temperatures and high pressures. Suitable protective clothing, along with face and eye protection must be worn. Refer to the health and safety guidelines for the machinery/equipment before installing this product. If in doubt, contact Land Instruments International.

Electrical Power Supply

Before working on the electrical connections, all of the electrical power lines to the equipment must be isolated. All the electrical cables and signal cables must be connected exactly as indicated in these operating instructions. If in doubt, contact Land Instruments International.

Storage

The instrument should be stored in its packaging, in a dry sheltered area.

Unpacking

Check all packages for external signs of damage. Check the contents against the packing note.

Lifting Instructions

Where items are too heavy to be lifted manually, use suitably rated lifting equipment. Refer to the Technical Specification for weights. All lifting should be done as stated in local regulations.

Contact Us

UK - Dronfield

Land Instruments International

Tel: +44 (0) 1246 417691

China

AMETEK Land China Service

Tel: +86 21 5868 5111 ext 122

USA - Pittsburgh

AMETEK Land, Inc.

Tel: +1 412 826 4444

India

AMETEK Land India Service

Tel: +91 - 80 67823240

Email: land.enquiry@ametek.com

Web: www.ametek-land.com

For further details on all AMETEK Land offices, distributors and representatives, please visit our website.

Return of Damaged Goods

IMPORTANT If any item has been damaged in transit, this should be reported to the carrier and to the supplier immediately. Damage caused in transit is the responsibility of the carrier not the supplier.

DO NOT RETURN a damaged instrument to the sender as the carrier will not then consider a claim. Save the packing with the damaged article for inspection by the carrier.

Return of Goods for Repair

If you need to return goods for repair please contact our Customer Service Department. They will be able to advise you on the correct returns procedure.

Any item returned to Land Instruments International should be adequately packaged to prevent damage during transit. See **Note** below for special packaging instructions relating to the P1200B.

You must include a written report of the problem together with your own name and contact information, address, telephone number, email address etc.

Design and Manufacturing Standards

The Quality Management System of Land Instruments International is approved to BS EN ISO 9001 for the design, manufacture and on-site servicing of combustion, environmental monitoring and non-contact temperature measuring instrumentation.

Registered ISO9001 Management System approvals apply in the USA

UK Calibration Laboratory: UKAS 0034

USA Calibration Laboratory: ANAB Accredited ISO/IEC 17025

National Accreditation Board for Testing and Calibration Laboratories approvals apply in India.

Operation of radio transmitters, telephones or other electrical/electronic devices in close proximity to the equipment while the enclosure doors of the instrument or its peripherals are open, may cause interference and possible failure where the radiated emissions exceed the EMC directive.

The protection provided by this product may be invalidated if alterations or additions are made to the structural, electrical, mechanical or pneumatic parts of this system. Such changes may also invalidate the standard terms of warranty.

Copyright

This manual is provided as an aid to owners of Land Instruments International's products and contains information proprietary to Land Instruments International. This manual may not, in whole or part, be copied, or reproduced without the expressed written consent of Land Instruments International Ltd.

Copyright © 2018 Land Instruments International.

NOTE

Before returning the P1200B, the cavity, cavity extension, positioning & support tubes must be removed from the source before being returned (and packed separately or held safely by the customer until the repair source is returned).

Contents

1	Introduction	1
2	Description	3
3	Specification	4
4	Electrical supply details	5
5	Commissioning	8
6	Using the Furnace	11
7	Calibration of Radiation Thermometers	14
8	Calibration of Thermocouples	16
9	Maintenance	17
10	Eurotherm Temperature Controller Type 2216CC	21
11	Spares	23
12	Accessories	23

1 Introduction

The LANDCAL Blackbody Source Type P1200B is designed for the testing and precise calibration of LAND radiation thermometers at temperatures in the range 150 to 1150°C.

The source is a primary standard black body for the high precision calibration of radiation thermometers. When the set point temperature is reached, the output from the thermometer under test is compared with the temperature of the source as measured by an optional Platinum thermocouple whose calibration is traceable to National Standards.

When used in conjunction with the Platinum thermocouple, which is supplied complete with a UKAS (United Kingdom Accreditation Service) calibration certificate, high precision is obtained. Alternatively, the source can be used in two other ways.

- 1) The temperature of the source can be measured by using a radiation thermometer of traceable calibration. This method of calibration can be described as calibration by comparison with a standard radiation thermometer. This method of calibration usually results in the most accurate as errors due to temperature gradients and non-black body conditions are eliminated.
- 2) If traceability to National Standards is not required, the source can be used without any certification. From previous work, the temperature as shown on the controller indication has been found to agree with the radiance temperature to within $\pm 10^\circ\text{C}$.

To simplify the lining up of LAND fixed installation radiation thermometers, an optical bench assembly is offered as an optional extra.



Uniform temperature conditions are achieved along the length of the cavity, which means that the source can also be used for the calibration of thermocouples by the comparison method.

1.1 Safety information

Every effort has been made during the design and manufacture of this furnace to ensure that it meets National and International standards of product safety. However great care should be shown by the user at all times when operating and maintaining high power furnaces which are capable of achieving high temperatures.

To reduce the risk of accident, follow the instructions listed below:

Warning

-  To avoid the possibility of electric shock, never expose the elements, terminals or other electrical components with the source connected to the mains supply. After completion of a repair, replace all safety plates before switching on the source.
-  To avoid the possibility of burns never attempt to dismantle the source until it has cooled to a safe temperature. This may involve an overnight wait.
-  This source contains no asbestos. The alumina-silicate (ceramic fibre) materials used release dust when disturbed which may, in some individuals, be an irritant to the skin, nose and throat.

Safety Note - Refractory Fibrous Insulation

Insulation made from High Temperature Insulation Wool Refractory Ceramic Fibre, (better described as Alumino Silicate Wool) (ASW)

This product contains alumino silicate wool products in its thermal insulation. These materials may be in the form of blanket or felt, formed board or shapes, mineral wool slab or loose fill wool. Whilst there is no evidence of any long term health hazards, we strongly recommend that safety precautions are taken whenever the materials are handled.

Exposure to fibrous dust may cause respiratory disease.

When handling the material always use an approved respiratory protection equipment (RPE-i.e. FFP3), eye protection, gloves and long sleeved clothing.

Avoid breaking up waste material. Dispose of waste in sealed containers.

After handling, rinse exposed skin with water before washing gently with soap (not detergent). Wash work clothing separately.

Before commencing any major repairs we recommend reference to the European Association representing the High Temperature Insulation Wool industry (www.ecjia.eu)

We can provide further information on request. Alternatively, our Service Department can quote for any repairs to be carried out, either at your premises or at Land Instruments International.

2 Description

The LANDCAL P1200P comprises a cylindrical, refractory closed end tube (cavity) approximately 300mm (12.0in) long, with an internal diameter of approximately 50mm (2.0in). The cavity is cast from silicon carbide and the closed end is angled at 120° to increase the emissivity value.

The cavity is placed horizontally in an electrically heated wirewound furnace. To improve the temperature uniformity of the furnace, three independent heater windings are employed. The temperature of the windings is measured by Nicrosil-Nisil (Type N) thermocouples and controlled using three digital PID controllers with negligible short term drift.

A standard Platinum thermocouple, possessing a traceability certificate (such as a UKAS certificate), can be inserted into the cavity from the rear of the furnace and used to determine the true temperature of the furnace. A second certificated thermocouple may be supplied and, when inserted into the cavity from the rear of the furnace, can be used to determine temperature gradients along the cavity.



Fig. 1 LANDCAL Blackbody Source Type P1200B

CA970262

3 Specification

Maximum working temperature:	1150°C (2100°F)
Recommended temperature range:	150 to 1100°C (300 to 2000°F)
Heating rate:	2 hours to 1000°C (1850°F)
Stability:	With the source controlling at temperature the radiance temperature will vary by less than $\pm 0.2^{\circ}\text{C}$ ($\pm 0.4^{\circ}\text{F}$) over a 60 minute period.
Uniformity:	The temperature gradients across the middle 40mm of the 50mm cavity are within $\pm 0.2^{\circ}\text{C}$ over the temperature range 200 to 1100°C
Radiation cavity	
Material:	Silicon Carbide
Inner diameter:	50mm (2.0in)
Internal length:	300mm (12.0in)
Length of sighting extension tube:	100mm (4.0in)
Emissivity:	0.998
Resistance heating element(s):	Resistance wire
Control thermocouple type:	Nicrosil-Nisil. Type N
Controller	
Master:	Eurotherm 2216 with RS 232 serial interface
Slaves:	Eurotherm 2216
Electrical supply:	220/240V a.c., 50 to 60 Hz. Part N° 135.183 110/120V a.c., 50 to 60 Hz. Part N° 135.193
Power consumption:	3.0kW (220/240V operation)
Measuring thermocouple (if supplied)	
Type:	B(6/30) or R(0/13) or S(0/10)
Length:	600mm (23.6in)
Sheath:	8 x 5 x 600mm
Overall dimensions	
Length:	725mm (28.5in)
Width:	350mm (13.8in)
Height:	535mm (21.1in)
Bench to tube centre height:	375mm (14.8in)
Weight:	
Nett:	33kg (73lb)
Gross:	43kg/95lb

The input a.c. power supply required for the particular furnace is specified on the furnace identity plate.



Note

The Eurotherm controllers fitted to the furnace are configured for °C operation. The zone controllers will not work correctly if reconfigured to work in °F.

4 Electrical supply details

4.1 Electrical connections

The furnace requires a single-phase a.c. supply with earth (ground). The supply may be Live to Neutral non-reversible, Live to Neutral with reversible plug, or Live to Live. Check that the supply voltage is compatible with the voltage on the furnace rating label.

The supply point must be within reach of the operator and must incorporate either an isolating switch, which operates on both conductors, or a quickly removable plug. The supply must incorporate an earth (ground).

The wiring diagrams for the P1200B are given in Fig. 2 and Fig. 3.

The power cable connection schedule is given in Table 1.

Cable Colour	Terminal Label	Supply Type Live-Neutral	Supply Type Reversible or Live-Live
Brown	L	To live	To either power conductor
Blue	N	To neutral	To the other power conductor
Green/Yellow	PE	To earth (Ground)	To earth (Ground)

Table 1 Power cable connection schedule

4.2 Fuses

Mains fuses (F1):
 220/240V operation, 13 Amps
 200/210V operation, 16 Amps
 110/120V operation, 32 Amps
 100V operation, 32 Amps

Instrument circuit fuses (F2): 20mm x 5mm, 2 Amps

Heat light fuses (F3): 20mm x 5mm, 2 Amps

4.3 Earth leakage



Warning

Take care when operating the furnace with an earth leakage trip in circuit. At high temperatures, all ceramic materials become slightly conductive. This may mean that at temperatures above 1000°C a leakage current in excess of 30mA is present. This will cause an earth leakage trip switch to activate.

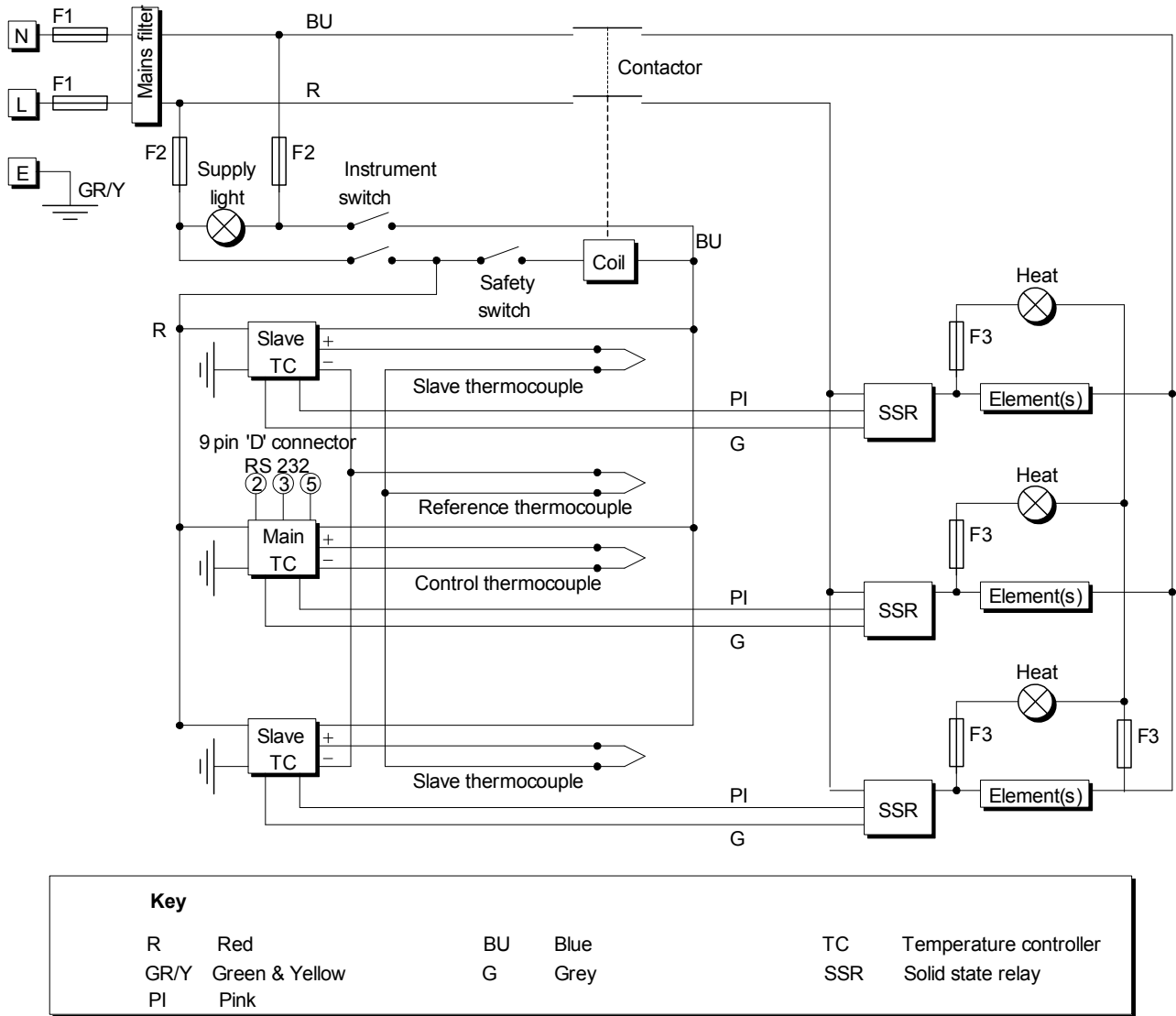
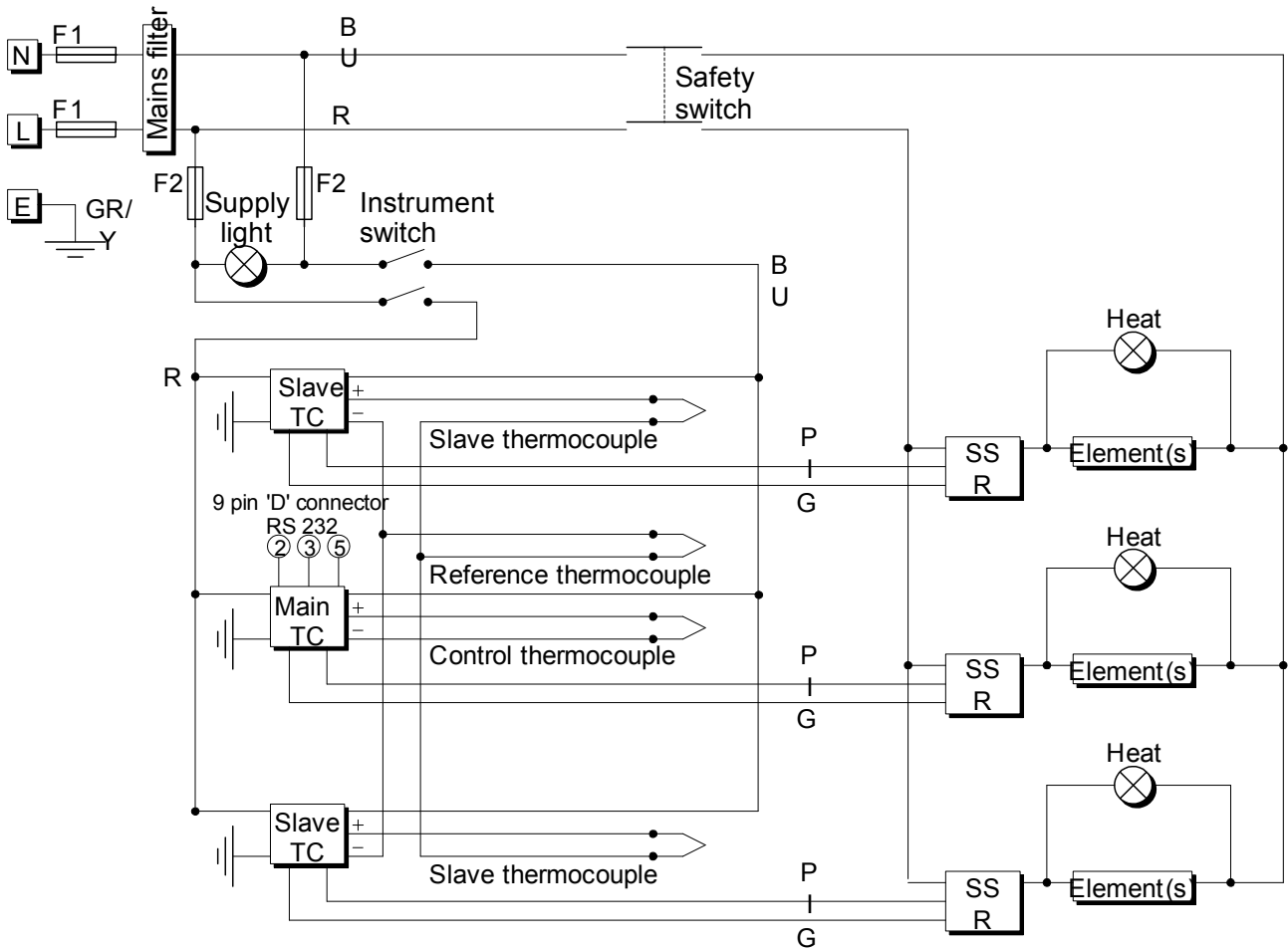

Fig. 2 Wiring diagram of the LANDCAL Blackbody Source, Type P1200B.
100 Volt and 110/120 Volt, single phase

CA970263



Key					
R	Red	BU	Blue	TC	Temperature controller
GR/Y	Green & Yellow	G	Grey	SSR	Solid state relay
PI	Pink				

Fig. 3 Wiring diagram of the LANDCAL Blackbody Source, Type P1200B.
200/220/240 Volt, single phase

CA970264

5 Commissioning

5.1 Inspection on receipt

Physically examine all items for any damage that may have occurred during transit. Check the contents against the packing note.

If any items have been damaged in transit, this should be reported to the carrier and to the supplier immediately, BUT DO NOT RETURN damaged items until the carrier has considered a claim. Save the packing with the damaged article for inspection by the carrier.

5.2 Furnace assembly

The following paragraphs describe the step by step procedure to prepare the furnace for switch on. Refer to Fig. 4.

To minimise the risk of damage to the furnace during transit, the cavity, cavity extension and positioning tube are supplied separately. If ordered, the measuring thermocouple(s) are also supplied separately. These items must be fitted as follows:

- 1) Remove the stainless steel front plate from around the furnace opening (4 screws).
- 2) Position the alumina positioning tube over the closed end of the cavity.
- 3) Locate the two lengths of mullite refractory tube into the lower grooves in the cavity.

The two tubes hold the cavity concentric between the heating elements. (These tubes may have been fixed for ease of assembly). The third groove in the cavity must be uppermost.

- 4) Slide the cavity into the furnace.
- 5) Ensure the thermocouple entry holes (from the rear of the furnace) are in line.
- 6) Slide the white insulated cavity extension into position.
- 7) Re-fix the stainless steel front plate into position.
- 8) Locate the thermocouple(s) in the 'measuring' (middle) and, if required, into the 'survey' (top) holes.

5.3 Heating up the furnace from cold

The central zone of the source is controlled directly by the master Eurotherm controller. Each end zone thermocouple is wired in opposition to a central reference thermocouple, and the small voltage resulting when the zones are at different temperature is used by the slave end zone controllers. After switching on the source, adjust the setpoint of the slave controllers to zero.

Using the master Eurotherm Controller

- 1) When switched on, the controller lights up, goes through a short test routine, then displays the measured temperature and starts to control. The output light glows or flashes when heating occurs.

- 2) To modify the set point, press the 'Up' or 'Down' button until the required value is obtained.

Note

All other controller parameters are factory-set and locked. For correct operation, it is not necessary to adjust any other parameters.

5.4 Using the RS232C Serial Interface Port

The source is supplied with a sub-miniature D-socket connected to the controller communication module to give RS232 serial communication. RS232 is suitable for direct connection to a personal computer (PC), using a cable configuration as shown below. The linked pins at the computer end are recommended, but may not be necessary.

The required cable is a 9-pin to connect to the furnace, and either a 9-pin or 25-pin to connect to the computer.

RS232 Cable: Furnace to PC connections

Furnace end of cable - female 9-pin	Computer end of cable - male 9-pin (25-pin)	
Rx 3 _____	3 (2)	Tx
Tx 2 _____	2 (3)	Rx
Com 5 _____	5 (7)	Com
	7,8 (4,5)	Link together
	1,4,6 (6,8,20)	Link together

The source is shipped with the RS232C communications protocol set to MODBUS, with the baud rate set to 9600 and no delay. The communication address is set to 1.

The source must only be connected and used with a PC by a person who understands how the serial communications function operates. If further information is required, either contact your local Eurotherm agent and request a copy of the Series 3000 Communication handbook, or consult the Eurotherm website.

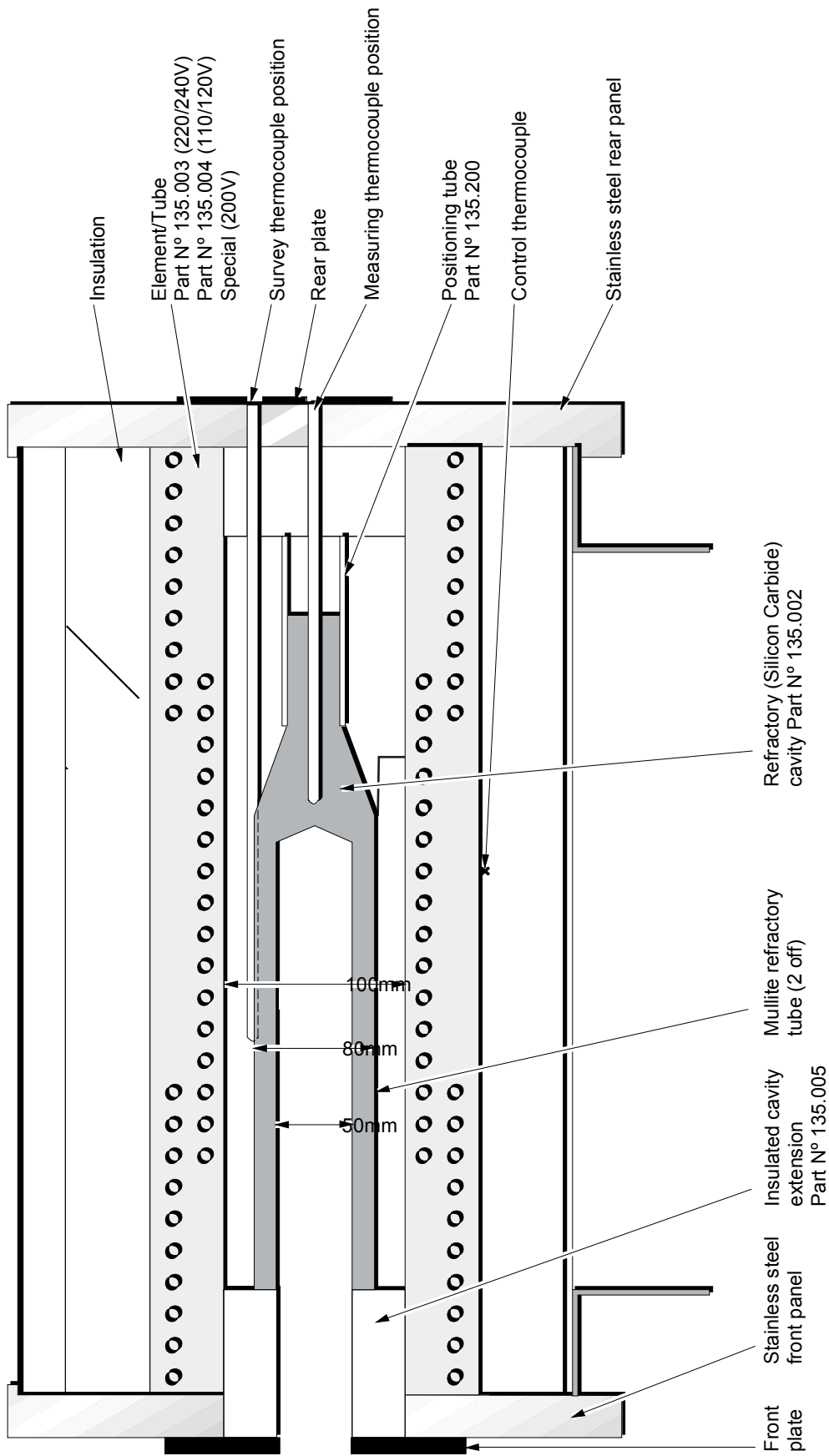

CA970265/B

Fig. 4 Furnace assembly drawing of the LANDCAL Blackbody Source Type P1200B

6 Using the Furnace

6.1 Introduction

The furnace is designed to create an enclosure of uniform temperature, ideal for the calibration of radiation thermometers or thermocouples. The cone point of the refractory cavity target block installed in the furnace is placed in the area of minimum gradients within the furnace. When calibrating radiation thermometers, the target size requirements of the thermometer must, whenever possible, be fulfilled by the cone. If the thermometer views the walls of the target block, results of greater uncertainty will be achieved. When calibrating thermocouples, the hot junctions must be inserted into the cone area and the furnace aperture plugged with ceramic fibre to reduce conduction and convection losses.

6.2 Measuring thermocouple

Provision has been made to measure the temperature of the target block using a Platinum thermocouple, which can be inserted from the rear of the furnace into the target. A 600mm (24.0in) long, recrystallised Alumina sheath must always be used to protect the thermocouple from mechanical damage and contamination. When placed in the measuring position, the thermocouple junction lies approximately 20mm (0.75in) behind the cone point. The temperature of the block, as measured by the thermocouple, agrees with the cone point radiance temperature to within the uncertainty of the thermocouple.

The output from the thermocouple must be measured via a cold junction enclosure of known temperature to an indicator or digital voltmeter having a resolution of 0.1°C.

This is the recommended way to obtain the true temperature of the target cavity. The temperature indication on the controller must not be used as an accurate measurement of target cavity temperature.

6.3 Survey thermocouple

An assessment of the temperature gradients down the length of the target can be carried out. This should only be necessary if doubt exists about the condition of the furnace, or if it is to be used for the most accurate calibration work which demands minimum temperature gradients. The temperature gradients within the furnace are dependant on control temperature, so if the furnace is used over a large temperature span, several assessments at different temperatures may be required.

To carry out a gradient assessment, a thermocouple must be fully inserted into the 'S' for survey (top) hole from the rear of the furnace. Refer to Fig. 4 for assistance with the position of the survey sheath.

After the thermocouple has achieved thermal stability, measure the temperature of the furnace with both the measuring and survey thermocouples. Withdraw the survey thermocouple (leave the sheath in position) by 20mm (0.75in), wait until the output stabilises and again measure the two temperatures. Repeat for a series of 5 to 10 survey thermocouple immersion depths, i.e. from fully inserted to 100 to 200mm (4.0 to 8.0in) back from full.

To determine the magnitude of the gradients, subtract the survey thermocouple temperature from the measuring thermocouple temperature. To show the gradients a graph can be plotted of gradient against position as shown in Fig. 5.

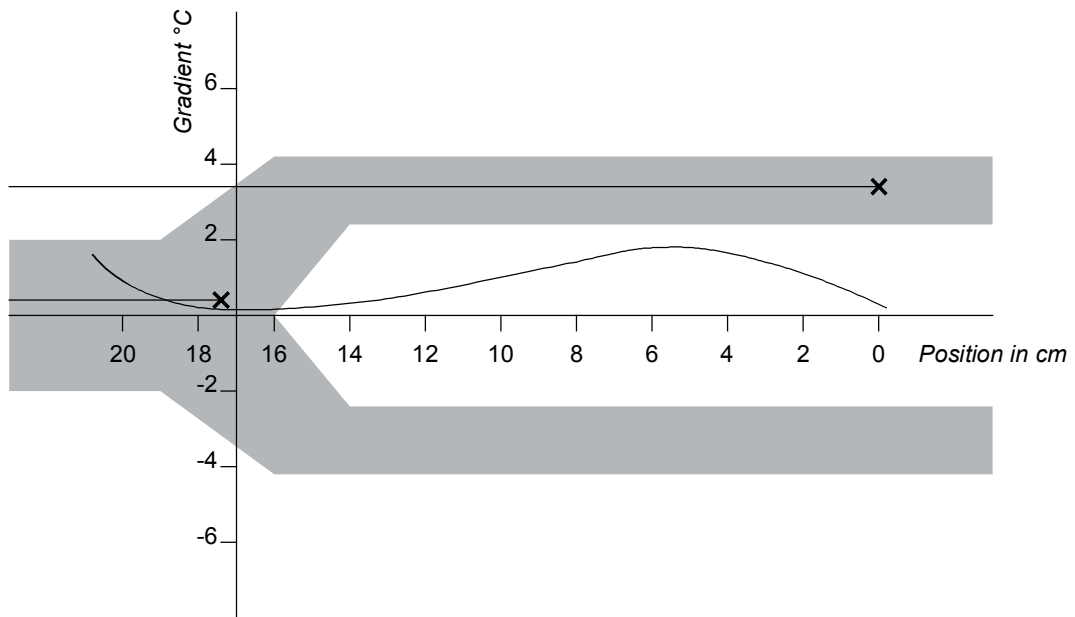

Fig. 5 Typical Gradients of a Furnace at 600°C/1100°F

CA970266

6.4 Control thermocouple

The thermocouple which controls the furnace temperature is situated close to the furnace heating element, which will be at a higher temperature than the target cavity. The difference between controller set point temperature and target cavity temperature can be as high as 10°C (20°F). In these cases, if a target temperature of 1000°C (1830°F) is required, it is necessary to adjust the controller setpoint to 1010°C (1850°F.)

The temperature indication on the controller must not be used as an accurate measurement of target cavity temperature.

6.5 Uniform temperature conditions

It is possible to reduce the gradients, and hence improve the uniformity, by setting the slave zone controllers to a value other than zero. After carrying out the survey as outlined in Section 6.3, if the gradients found are excessive, then increase/decrease the slave zone controller settings and, after waiting for the furnace to achieve stability, repeat the survey. A third or fourth survey may be necessary to achieve optimum controller settings. The temperature gradients within the furnace are dependant on the control temperature. If the furnace is used over a wide temperature span several assessments at different temperatures may be required.



NOTE

The slave controllers work in conjunction with the main zone controller and supply more power (positive value to increase the zone temperature) or less power (negative value to decrease the zone temperature). They are both scaled ± 50 , which means that if the furnace temperature is set with the main zone controller at 1200°C (2200°F) and the slave zone controllers at +50, the booster winding will be operating at 1250°C (2300°F). This is approaching the melting point of the wire and continual use in this way will cause premature failure of the element.

Experience has shown that it should not be necessary to set the rear zone controller at a value higher than +30 and the front zone at a value higher than +50. When operating the furnace at a temperature higher than 1100°C (2000°F), set both slave zone controllers to zero.

7 Calibration of Radiation Thermometers

7.1 Preparation

The furnace control setting will usually be the normal working temperature of the thermometer to be tested.

The target temperature is that indicated either by the standard thermocouple in the 'measuring' position, or as indicated by a standard radiation thermometer.

A convenient method of holding a fixed system radiation thermometer is to mount a holder horizontally onto an optical bench assembly having vertical and transverse vernier adjustments. Portable radiation thermometers are usually hand held.

Position the holder on the optical bench to obtain the desired distance between target and thermometer. Adjust the vertical and transverse vernier screws to align the holder correctly.

To reduce unnecessary heating from furnace radiation, it is recommended that a heat shield be placed between furnace and holder, and only removed during periods when outputs from the thermometers are being measured. Ensure that the shield is away from the sighting tube so that furnace conditions are not altered when it is removed.

7.2 Thermometer calibration

When soaked conditions have been obtained, place the radiation thermometer under test in the holder, remove the heat shield and measure the thermometer output on the measuring apparatus. Immediately afterwards, measure the temperature of the furnace.

Convert the thermometer output into temperature, by reference to the relevant calibration tables, and compare with the furnace temperature.

7.3 Accuracy of calibration

The source has been designed for the accurate calibration of LAND radiation thermometers. The accuracy that can be achieved by using the source is dependent on:

- 1) The uncertainty of calibration and resolution of the measuring thermocouple/standard radiation thermometer
- 2) The emissivity of the source
- 3) The resolution of the thermometer under test

The uncertainty specified on the calibration certificate issued by the calibration laboratory will be a function of:-

- 1) The calibration laboratory's capabilities
- 2) The type of thermocouple or radiation thermometer tested
- 3) The temperature range covered

Values of $\pm 1\text{K}$ ($\pm 2^\circ\text{F}$) up to 1100°C (2000°F) and $\pm 2\text{K}$ ($\pm 4^\circ\text{F}$) over the range 1100 to 1600°C (2000 to 2900°F) are typical for the uncertainty.

A value of $\pm 0.1\text{K}$ to $\pm 1\text{K}$ ($\pm 0.2^\circ\text{F}$ to $\pm 2^\circ\text{F}$) should be specified for the resolution, depending on the type of measuring equipment used.

As the emissivity of the source is less than 1.00, the radiance temperature will be dependent on the wavelength of the thermometer under test. For example, a furnace operating at 1000°C (1832°F) with emissivity of 1.00 will show a temperature of 1000°C (1832°F) for a thermometer having a silicon cell (wavelength = $1\mu\text{m}$) detector and a temperature of 1000°C (1832°F) for a thermometer having a pyroelectric (wavelength = 8 to $14\mu\text{m}$) detector.

However, a furnace operating with emissivity of 0.998 at 1000°C (1832°F) will show a temperature of 999.8°C (1831.6°F) for a thermometer having a silicon cell detector and a radiance temperature of 998.5 (1829.3°F) for a thermometer having a pyroelectric detector.

Most hand held thermometers and fixed installation thermometers used in conjunction with an indicator have a resolution of $\pm 1\text{K}$ ($\pm 2^\circ\text{F}$). Fixed installation thermometers, whose output is measured on a digital voltmeter, will have a resolution of between $\pm 0.1\text{K}$ and $\pm 0.5\text{K}$ ($\pm 0.2^\circ\text{F}$ and $\pm 1.0^\circ\text{F}$).

To determine the best measurement capability, the uncertainty of each individual measurement component must be added together. Typical values at 1000°C are between $\pm 3\text{K}$ and $\pm 5\text{K}$ ($\pm 6^\circ\text{F}$ and $\pm 10^\circ\text{F}$).

7.4 Calibration procedures

When calibrating radiation thermometers, it is important to follow documented step-by-step procedures to ensure that specified calibration conditions such as calibration distance, furnace temperature and aperture size are always met.

If you experience any difficulty in writing your own procedures, LAND can offer guidance as to which calibration conditions must be adopted for LAND products.

8 Calibration of Thermocouples

8.1 Introduction

Uniform temperature conditions are achieved along the length of the cavity, which allows the furnaces also to be used for the calibration of thermocouples by the comparison method. This method consists of comparing the thermocouple under test with a standard thermocouple, the calibration of which is traceable to National Standards.

As well as a uniform temperature source, basic equipment requirements would be a set of standard thermocouples, a reference (cold junction) source and a digital voltmeter for measuring the outputs from the thermocouples.

8.2 Thermocouple calibration

The test and standard thermocouples are placed in close proximity in the uniform temperature zone of the furnace. After allowing the thermocouples to soak at temperature, readings of output are noted. Hence the test thermocouple has been directly compared with the standard.

9 Maintenance

9.1 Introduction

- 1) Before starting any maintenance/repair work, always ensure that the furnace is disconnected from the electricity supply.
- 2) Before starting any maintenance/repair work, always ensure that the furnace has been allowed to cool to room temperature.
- 3) Upon completion of any furnace maintenance work, check the furnace for electrical safety before use.

9.2 Routine Servicing

The source is fully tested and evaluated before supply and should give years of trouble-free operation. No regular servicing or maintenance is required. The furnace outer surface can be cleaned with a damp cloth. Do not allow water to enter the case. Do not clean with organic solvents. In the unlikely event of a failure, return the source either to a LAND company directly, or to one of the LAND distributors for repair. The instructions in the following sections provide information for the customer replacement of the heating element and the replacement of other consumable items. Adjustment of the power setting may be required from time to time.

9.3 Replacing the control thermocouple

- 1) Remove the front and rear stainless steel panels and the outer mesh from the furnace body.
- 2) Remove the cylindrical body from the base. To reach the bolts or screws which fix the body to the base, remove the back panel from the base.
- 3) Disconnect the thermocouple from its terminal block. Make a note of the thermocouple connections. The negative leg of the thermocouple is marked blue. Compensating cable colour codings are:
Negative Positive (type N)
White Pink
It may help to release the terminal block from the furnace, retaining any porcelain spacers.
- 4) Withdraw the thermocouple from its sheath (the narrow-bore wound-in tube) and remove any broken bits of thermocouple.
- 5) Bend the new thermocouple carefully to match the shape of the original (working from the terminal end). If there is a small difference in thermocouple length ensure that the distance from the tip to the first bend is the same.
- 6) Insert the new thermocouple into position and reconnect, restoring any removed porcelain spacers, and ensuring correct polarity: blue to white.
- 7) Reassemble the furnace.

9.4 Replacing current fuses

Access to internal fuses is by removal of the back panel.

9.5 Replacing the temperature controller

To replace the temperature controller, ease apart the two lugs at the side, grip the instrument and withdraw it from its sleeve. Push in the replacement. Before handling the controller wear an anti-static wrist strap to avoid any possibility of damage by static electricity.

9.6 Replacing solid state relays

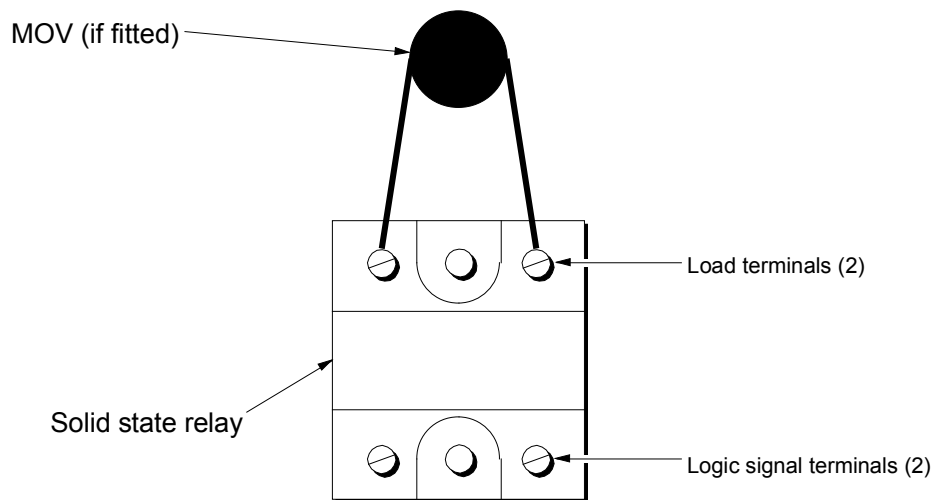

Fig. 6 Solid state relay connections

CA970270

- 1) Disconnect the furnace from the electrical supply.
- 2) Remove the rear panel from the furnace or control cabinet and locate the solid state relay(s), removing any other panels necessary to give reasonable access to the relay(s).
- 3) Disconnect the four or five wires, noting their numbers and positions.
- 4) Remove the faulty relay and replace it with a new one, noting which way round to fit it.

Original relays are fitted with a thin layer of 'off-white' paste to give good heat transfer to the aluminium sheet. New relays are supplied with a heatsink 'pad'. All remnants of the old heatsink paste must be removed. The thin white heatsink pad must be fitted between the solid state relay and the plate to which it is mounted.

- 5) Tighten the two fixing screws.
- 6) Refit the wires as noted in (iii) above. If the replacement solid state relay is supplied with a metal oxide varistor (MOV) it must be connected between the load terminals as shown in Fig. 6. It is not polarity dependent. The MOV protects the SSR from short periods of excess voltage. If the replacement SSR is supplied without an MOV this is because the MOV is built-in on later versions.
- 7) Replace the panels.
- 8) Reconnect the furnace to the electrical supply.

9.7 Replacing furnace elements

- 1) Remove the front and rear stainless steel panels and outer mesh from the furnace body.
- 2) Remove the cylindrical body from the base; to reach the bolts or screws which fix the body to the base, remove the back panel from the base.
- 3) Disconnect all electrical leads from the terminal blocks on the furnace case. Note the colours and positions of the connecting leads to enable correct reassembly. Take care not to crack the porcelain terminal blocks - use two spanners where appropriate.
- 4) Remove the thermocouples; ensure that the matching terminal blocks and thermocouples are correctly recorded.
- 5) Lay the furnace body horizontally with the split in the cylindrical case uppermost.
- 6) Remove the two metal end-caps from the body.
- 7) Remove the self-tapping screws which hold the terminal strip to the case join; the case will spring open slightly.
- 8) Remove the ceramic board discs from both ends.
- 9) Check to see if the insulation is entirely of fibre blanket i.e. is a soft material. If so, use a sharp knife to cut right through the insulation down to the wirewound tube element along the whole length of the body. The knife cut must be in line with the element lead wires.
- 10) Slide the element gently out through the end of the furnace body.
- 11) If the insulation comprises two vacuum-formed half-shells, i.e. lightweight, but more rigid material containing the element wrapped with a thin layer of blanket, slide out the whole assembly.
- 12) Clean out the cylindrical case, removing any loose pieces of refractory cement which may have fallen off the old element.
- 13) Remove the insulation beads from the tails of the old element and fit them to the replacement element.
- 14) Slide in the new element, complete with the half-shells where appropriate.
- 15) Close up the furnace again, refitting the terminal strip (where applicable) and the end-caps. Ensure that any cut made in the insulation closes up completely: if the insulation appears loose or damaged in any way, please contact the Land Infrared Service Department.
- 16) Refit the ceramic board discs to both ends of the furnace body.
- 17) Replace and tighten the self-tapping screws which hold the terminal strip to the case join.
- 18) Refit the two metal end-caps onto the body.
- 19) Replace the thermocouples, ensuring that the correct connections are made between the terminal blocks and thermocouples.
- 20) Reconnect all electrical leads to the terminal blocks on the furnace case, referring to the notes made in step 3 for the colours and positions of the connecting leads to enable correct reassembly. Take care not to crack the porcelain terminal blocks - use two spanners where appropriate.
- 21) Attach the cylindrical body to the base via the bolts or screws located behind the back panel.

- 22) Refit the outer end caps and the outer mesh onto the furnace body.
- 23) To rule out the possibility that the element failed because of a fault elsewhere in the electrical system, check that the furnace is controlling properly.
- 24) Let the furnace heat up at its maximum rate to 900°C (1652°F) without interruption, and then soak for 1 hour. This must be done in conditions of good ventilation.

10 Eurotherm Temperature Controller Type 2216CC

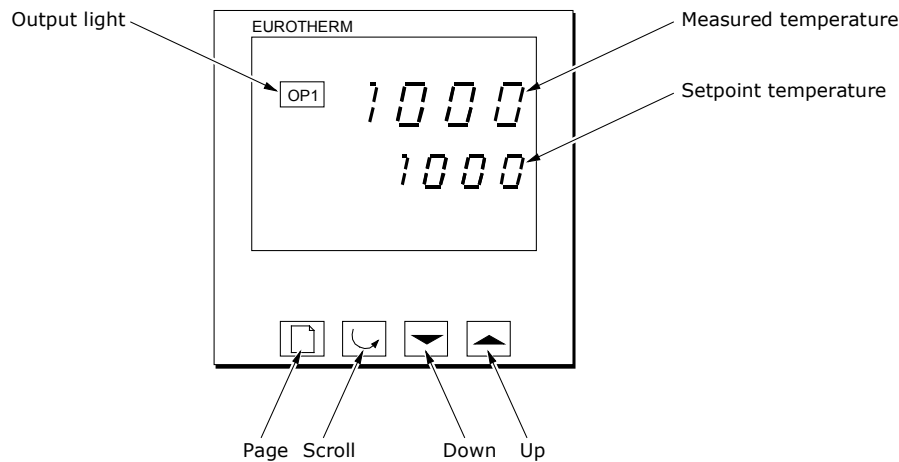

Fig. 13 'Eurotherm' Controller - front panel controls

301014

10.1 Introduction

When switched on, the controller lights up, goes through a short test routine, and then displays the measured temperature and starts to control. The output light glows or flashes as heating occurs.

In **Level 1** operation, both the setpoint temperature and the actual measured temperature are displayed.

The **Page** key allows access to the **Level 2** mode of operation. When in **Level 2**, the parameter lists within the controller can be displayed.

The **Scroll** key allows access to the adjustable parameters within the controller. Most lists and parameters are hidden and cannot be accessed by the operator even when in **Level 2** mode of operation. These hidden features contain factory-set parameters which should not be changed.

The **Up** and **Down** keys are used to alter the setpoint temperature in **Level 1** operation and parameter values when in **Level 2** operation.

To enter the **Level 2** mode of operation:

- 1) Press and hold the **Page** key for 3 seconds.
- 2) The display will show **Leu 1 Goto**. Release the **Page** key.
- 3) Press the **Up** or **Down** button to choose **Leu 2** (Level 2).
- 4) Press the **Up** or **Down** button to enter the Level 2 access code, which is **9**.
The Home page is displayed.

The parameters within Level 2 are:

- 1) Press the scroll button. **WRK.OP** (working output) is displayed.
- 2) Press the scroll button. **SP.RAT** (setpoint rate limit) is displayed. This is set to **OFF**, but is adjustable.
- 3) Press the scroll button. **OP.HI** (maximum power output setting) is displayed. This is set to **100.0**, but is adjustable downwards.
- 4) Press the scroll button. **ADDR** (communications address) is displayed.

This is set to **1** and is adjustable.

To return to the Level 1 mode of operation:

- 1) Press and hold the **Page** key.
- 2) Press the down key to select **Leu 1**.

10.2 Altering the Setpoint

- 1) Press either the **Down** or **Up** key once to display the setpoint.
- 2) Use the **Down** or **Up** key to adjust the setpoint value.
The display returns to the measured temperature when no key is pressed for 0.5 seconds.

10.3 Altering the Ramp Rate

- 1) Press the **Scroll** key until **SP.RAT** (SetPoint ramp rate) is displayed.
- 2) Use the **Down** or **Up** key to adjust the ramp rate value.
The ramp rate sets the maximum rate of heating or cooling in degrees per minute. A value of **OFF** cancels the ramp rate, allowing heating and cooling at the maximum rate. **OFF** is the default setting.

10.4 Altering the Power Limit (when applicable)

- 1) Press the **Scroll** key until **OP.Hi** (Output High) is displayed.
- 2) Press the **Down** key once to display the value of **OP.Hi ...and write down the value.**

Warning

Do not increase the value without correct calculation: the furnace elements or wiring could burn out.

- 3) To alter the value, use the **Down** or **Up** key. Do not set the value to zero: this will prevent the furnace from heating.

10.5 Altering the Communication Address

- 1) Press the scroll key until **Addr** (address) is displayed.
- 2) To alter the value press the **Down** or **Up** key.

The display returns to the measured temperature when no key is pressed for 45 seconds.

Warning

Do not alter any other parameters.

11 Spares

The spare parts listed below are available for use with the Landcal Blackbody Source Type P1200B:

Description	Land Part N°
Silicone Carbide Cavity	135.002
Heating Elements/Tube 220/240 Volt	135.003
Heating Elements/Tube 110/120 Volt	135.004
Insulated Cavity Extension	135.005
Solid State Relay	135.006
Measuring Thermocouple (0.6m) UKAS	Type R 135.152
	Type S 135.153
	Type B 135.154
Positioning Tube - RCA 54 x 45 x 178mm long	135.200

12 Accessories

An Optical Bench calibration accessory (Land Part N° 135.204) is available for use with the Landcal Blackbody Source, type P1200B.

Mounted onto the 36in / 915mm long optical bench are vertical and horizontal adjustment positioners, which allow precise alignment of Land radiation thermometers. The accessory is supplied with the following items:

- A thermometer jacket holder suitable for mounting Land System 3 thermometers.
- This holder can also be used for mounting Land Solo and Land Micratherm thermometers.
- A separate holder for mounting Land System 4 thermometers.
- This holder can also be used for mounting Land Fibroptic type thermometers.
- The holders are fitted with quick-release connectors.

LAND

AMETEK[®]
PROCESS & ANALYTICAL INSTRUMENTS

PRODUCT WARRANTY

Thank you for purchasing your new product from Land Instruments International. This Land manufacturer's 'back-to-base' warranty covers product malfunctions arising from defects in design or manufacture. The warranty period commences on the instrument despatch date from the Land Instruments International Ltd. factory in Dronfield, UK.

36 MONTHS WARRANTY



Building upon the reputation for reliability and longevity that System 4 and UNO thermometers have earned, Land are delighted to be able to provide our customers with an industry-leading 36 month warranty for the following products:-

- SPOT thermometers, accessories* and mountings* and special instruments based on SPOT.
**Note: SPOT Actuators are provided with an 18 months Warranty.*
- System 4 thermometers, processors, accessories and mountings and special instruments based on System 4.
- UNO thermometers, accessories and mountings and special instruments based on UNO.
- Application-dedicated processors based on LANDMARK[®] Graphic.
- ABTS/S and ABTS/U
- FTS
- VDT/S and VDT/U
- DTT
- FLT5/A

This 36 month warranty is provided as standard for all orders for the products listed above received from 1st May 2002.

We believe that our customers expect us to set the standard in terms of performance, quality, reliability and value for money. This 36 months warranty, as a part of an on-going program of continuous improvement, is just one way in which Land strive to maintain our position as the temperature measurement partner of choice.

24 MONTHS WARRANTY

The following Land Instruments International products are provided with a 24 months warranty:

- ARC
- FTI-E
- NIR

18 MONTHS WARRANTY

The following Land Instruments International products are provided with an 18 months warranty:

- SPOT Actuator

12 MONTHS WARRANTY

All Land Instruments International products not provided with either a 36, 24 or 18 month warranty (see lists above), are provided with a 12 months warranty.

PRODUCT WARRANTY

EXCLUSIONS FROM WARRANTY

It should be noted that costs associated with calibration checks which may be requested during the warranty period are not covered within the warranty.

Land reserve the right to charge for service/calibration checks undertaken during the warranty period if the cause is deemed to fall outside the terms of the warranty.

This Land manufacturer's warranty does not cover product malfunction arising from:-

- incorrect electrical wiring.
- connection to electrical power sources outside the rating of the product.
- physical shock (being dropped, etc.) and impact damage.
- inappropriate routing, support, physical shock & strain protection, etc. of the lightguide (Fiberoptic thermometers only).
- environmental conditions exceeding the IP / NEMA rating of the product.
- environmental conditions outside the Ambient Temperature, Humidity and Vibration rating of the product.
- environmental contamination (solvent vapours, deposition of airborne contamination, cooling liquids of non-neutral pH, etc.).
- overheating as a result of interruption of water/air flow through cooling jackets or of incorrect installation.
- inappropriate modification of product (drilling holes in thermometer bodies, etc.).
- inappropriate recalibration which results in product calibration being taken outside specification.
- improper resealing of thermometer following parameter adjustment (UNO, FLT5/A, etc.).
- attempted repair by a non-Land-authorized repair centre.

Land Instruments International Ltd • Dronfield S18 1DJ • England • Tel: +44 (0) 1246 417691 • Fax: +44 (0) 1246 410585
Email: land.enquiry@ametek.com • www.landinst.com

AMETEK Land, Inc. • 150 Freeport Rd. • Pittsburgh, PA 15238 • U.S.A. • Tel: +1 (412) 826 4444
Email: irsales@ametek.com • www.ametek-land.com

For a complete list of our international offices, please visit www.landinst.com

Issue 5: 14 February 2018