

LAND

Measuring temperature of Optical Fibre Drawing Tower Furnace



In order to draw high quality low loss optical fibre with the required strength and attenuation, the temperature of the drawing tower furnace must be stable and precisely controlled.

The furnace lining can get close to melting point so its temperature is monitored and used as the heating control parameter.

Measurement Problems

Graphite resistance and Induction-heated zirconia furnaces operating at high temperatures, typically 2200°C/4000°F, make contact methods of temperature measurement impractical.

The thermometer requires a small target size to view between the coils in an induction heated furnace, or sight down a narrow tube on to the zirconia susceptor.

In the case of a graphite resistance type furnace the thermometer has to sight through a quartz window, down through a narrow tube onto the heating element.

Experience has shown outstanding benefits by using short wavelength thermometers, for this application in order to achieve maximum accuracy.

A silicon cell detector gives high stability, rapid response and high rate of change of output with temperature.

A small target size is offered, with a measurement spot size of 4mm diameter at the focus distance of 450mm.

The thermometer provides high level signal to noise output for retransmission to a readout or control system.

Individually calibrated thermometers are available with traceability to National Standards. UKAS or NIST Calibration certificates are available.

Features

- 2m light guide length
- Small target capability
- Rugged, flexible, modular design
- Accurate, reliable, drift-free measurement
- Industry standard outputs to suit any process monitoring, recording or control system
- Standard industry mounting

Specifications DTT Drawing Tower Thermometer

Model:	DTT 800/2600C	DTT 1500/4700F
Temperature range Operating: Specified:	800 to 2600°C 1000 to 2600°C	1500 to 4700°F 1830 to 4700°F
Wavelength:	1µm	
Response time:	Adjustable 5ms to 5s (0 to 95%)	
Emissivity:	Emissivity adjustable 0.10 to 1.00	
Output:	4 to 20mA	
Field of view (Nominal):	112:1	
Target dia: DT1 optic head:	4mm at 450mm	0.15in at 17.7in
Accuracy Repeatability: Absolute:	≤2°C/4°F ≤0.75%K	
Stability Temperature:	0.3°/°amb	
Time:	2°C/year	4°F/year
Vibration:	3g any axis, 10 to 300Hz	
Humidity:	0 to 99% non condensing	
Sealing:	To IP65 requirements	To NEMA 4X requirements
Ambient temperature Optic head: Lightguide:	200°C 200°C	392°F 392°F
Detector Specified: Operating:	0 to 70°C -10 to 80°C	32 to 158°F 14 to 176°F
Weight:	1.7kg	3.75lb
CE:	EN 50-082-2 (immunity), EN 50-081-1 (emission), IEC 1010 (safety)	

Specifications

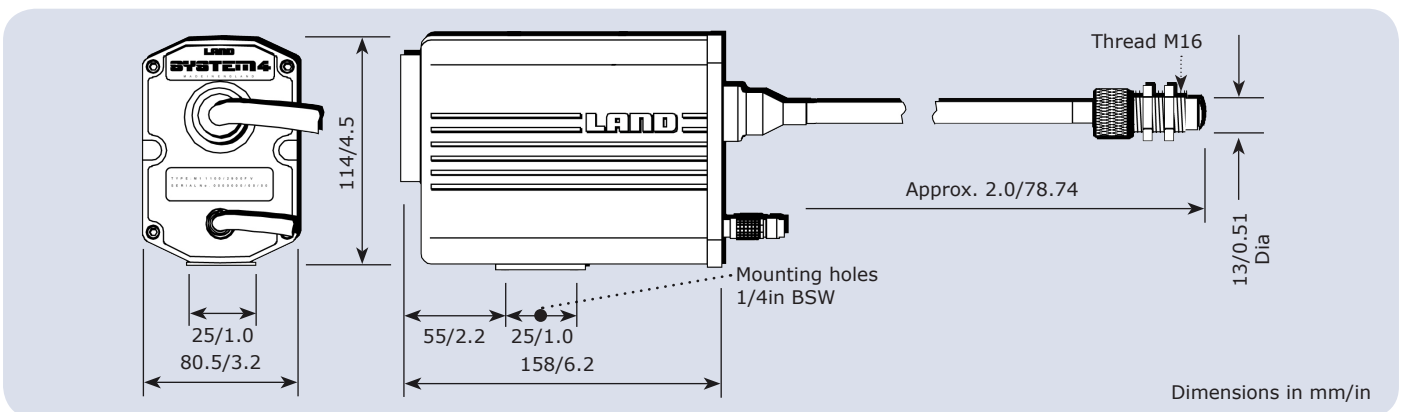

LAND

Non-Contact Temperature Measurement Solutions

AMETEK®

Land Instruments International Ltd • Dronfield S18 1DJ • England
Email: land.infrared@ametek.co.uk • www.landinst.com • Tel: +44 (0) 1246 417691 • Fax: +44 (0) 1246 410585

AMETEK Land, Inc. • 150 Freeport Rd • Pittsburgh, PA 15238 • U.S.A.
Email: irsales@ametek.com • www.ametek-land.com • Tel: +1 (412) 826 4444 • Fax: +1 (412) 826 4460

For a full list of international offices, please visit www.landinst.com



0034



Applies in the UK



001



LABORATORY ACCREDITATION BUREAU ACCREDITED

REGISTERED
ISO 9001
MANAGEMENT SYSTEM

Applies in the USA