

NIR-656 / NIR-2K

INSTALLATION GUIDE

PUBLICATION N° 814089

LANGUAGE: ENGLISH

ISSUE: 1

DATE: 01 FEBRUARY 2021

📌 NIR-656 / NIR-2K Camera



Health and Safety Information



Read all of the instructions in this booklet - including all the **WARNINGS** and **CAUTIONS** - *before* using this product. If there is any instruction which you do not understand, **DO NOT USE THE PRODUCT.**

Safety Signs



WARNING

Indicates a potentially hazardous situation which, if not avoided, could result in death or personal injury.



CAUTION

Indicates a potentially hazardous situation which, if not avoided, could result in minor or moderate injury to the user or users, or result in damage to the product or to property.

NOTE

Indicates a potentially hazardous situation which, if not avoided, could result in damage or loss of data.

Signs and Symbols used on equipment and Documentation



Caution, risk of electric shock.



Caution, attention to possibility of risk of damage to the product, process or surroundings. Refer to instruction manual.



Caution, hot surface.



Protective Conductor Terminal.



Observe precautions for handling electrostatic discharge sensitive devices.

Equipment Operation

Use of this instrument in a manner not specified by AMETEK Land may be hazardous. Read **and understand** the user documentation supplied **before** installing and operating the equipment.

The safety of any system incorporating this equipment is the responsibility of the assembler.

Protective Clothing, Face and Eye Protection

It is possible that this equipment is to be installed on, or near to, machinery or equipment operating at high temperatures and high pressures. Suitable protective clothing, along with face and eye protection must be worn. Refer to the health and safety guidelines for the machinery/equipment before installing this product. If in doubt, contact AMETEK Land.



Wear Protective Gloves



Wear Protective Clothing



Wear Eye Protection



Wear Ear Protection



Wear Safety Boots



Wear Face Protection

Electrical Power Supply

Before working on the electrical connections, all of the electrical power lines to the equipment must be isolated. All the electrical cables and signal cables must be connected exactly as indicated in these operating instructions. If in doubt, contact AMETEK Land.

Contact Us

UK - Dronfield

Land Instruments International

Tel: +44 (0) 1246 417691

China

AMETEK Land China Service

Tel: +86 21 5868 5111 ext 122

USA - Pittsburgh

AMETEK Land, Inc.

Tel: +1 412 826 4444

India

AMETEK Land India Service

Tel: +91 - 80 67823240

Email: land.enquiry@ametek.com

Web: www.ametek-land.com

For further details on all AMETEK Land offices, distributors and representatives, please visit our website.

Storage

The instrument should be stored in its packaging, in a dry sheltered area.

The maximum storage temperature is 10°C (18°F) higher than the maximum operating temperature.

The minimum storage temperature is 10°C (18°F) lower than the minimum operating temperature.

Refer to the Technical Specification for details of the operating temperature limits.

Unpacking

Check all packages for external signs of damage. Check the contents against the packing note.

Lifting Instructions

Where items are too heavy to be lifted manually, use suitably rated lifting equipment. Refer to the Technical Specification for weights. All lifting should be carried out in accordance with local and national regulations.

Return of Damaged Goods

IMPORTANT If any item has been damaged in transit, this should be reported to the carrier and to the supplier immediately. Damage caused in transit is the responsibility of the carrier not the supplier.

DO NOT RETURN a damaged instrument to the sender as the carrier will not then consider a claim. Save the packing with the damaged article for inspection by the carrier.

Return of Goods for Repair

If you need to return goods for repair please contact our Customer Service Department for details of the correct returns procedure.

Any item returned to AMETEK Land should be adequately packaged to prevent damage during transit.

You must include a written report of the problem together with your own name and contact information, address, telephone number, email address etc.

Design and Manufacturing Standards

The Quality Management System of Land Instruments International is approved to BS EN ISO 9001 for the design, manufacture and on-site servicing of combustion, environmental monitoring and non-contact temperature measuring instrumentation.

Registered ISO9001 Management System approvals apply in the USA.

UK Calibration Laboratory: UKAS 0034.

USA Calibration Laboratory: ANAB Accredited ISO/IEC 17025.

National Accreditation Board for Testing and Calibration Laboratories approvals apply in India.

Operation of radio transmitters, telephones or other electrical/electronic devices in close proximity to the equipment while the enclosure doors of the instrument or its peripherals are open, may cause interference and possible failure where the radiated emissions exceed the EMC directive.

The protection provided by this product may be invalidated if alterations or additions are made to the structural, electrical, mechanical, pneumatic, software or firmware components of this system. Such changes may also invalidate the standard terms of warranty.

Copyright

This manual is provided as an aid to owners of AMETEK Land's products and contains information proprietary to AMETEK Land. This manual may not, in whole or part, be copied, or reproduced without the expressed written consent of AMETEK Land.

Contents

1	Introduction	1
1.1	About the NIR-656/NIR-2K Thermal Imager	3
1.2	Unpacking the Thermal Imager	3
1.3	Nomenclature	3
2	Specifications	4
2.1	Imager Performance	4
2.2	Mechanical & Environmental	4
2.3	Electrical	5
2.4	Image Processing	5
2.5	Standard Accessories	5
3	Installing the Thermal Imager	6
3.1	Fields of View	8
3.2	Thermal Imager installation dimensions	8
4	Electrical Connections	10
4.1	Connecting the mains input to the TRACO Power Supply Unit	11
4.2	Using an alternative Power Supply Unit	12
4.3	Ethernet Communications (Gig-E) Data Output	13
5	Using the Thermal Imager	14
5.1	Focusing the thermal imager onto the target	14
6	Spares & Accessories	15

1

INTRODUCTION

This Installation Guide gives instructions on how to install the AMETEK Land NIR-656 / NIR-2K Fixed Thermal Imaging System. The system is operated from *IMAGEPro* or *IMAGEViewer* software, both of which are available from AMETEK Land. These instructions are provided as a series of simple installation diagrams, covering the installation of the NIR-656 / NIR-2K thermal imaging camera and its mountings, accessories and services.

The equipment must be used, maintained and serviced by properly trained personnel, capable of following the procedures given in these instructions. Safety may be impaired if the system is not used as indicated.

It is important to check the equipment with which you have been supplied and then read these instructions thoroughly before proceeding with operation.

There are two basic installed configurations covered by this guide.

Control Computer Installation

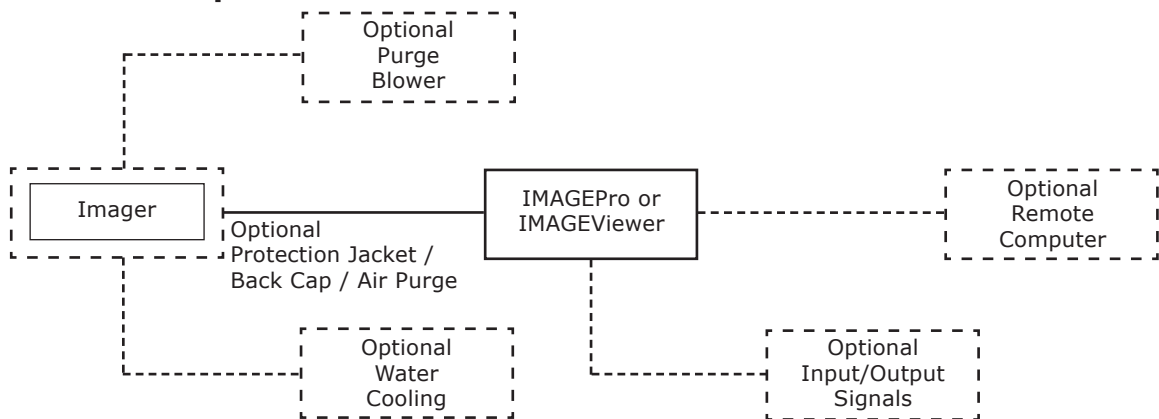

PSU Installation

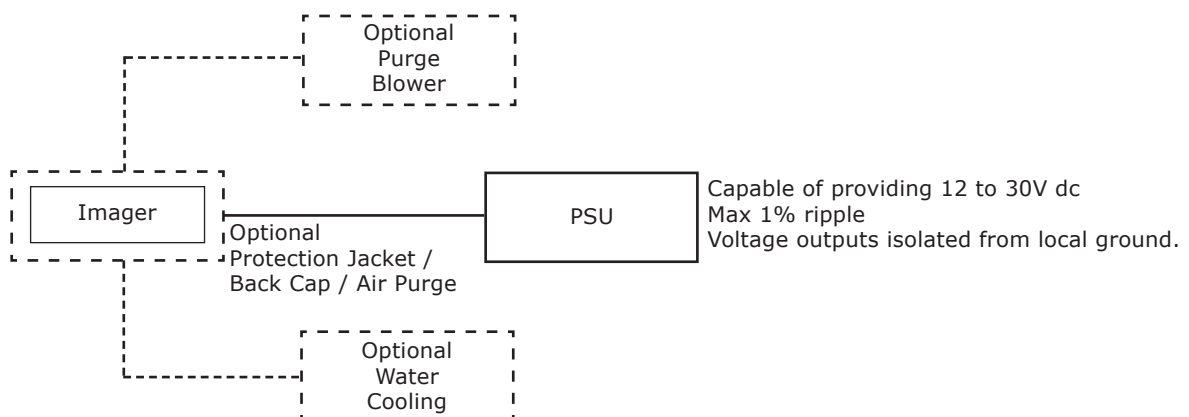



Fig. 1-1 AMETEK Land NIR-656/NIR-2K Thermal Imaging Camera

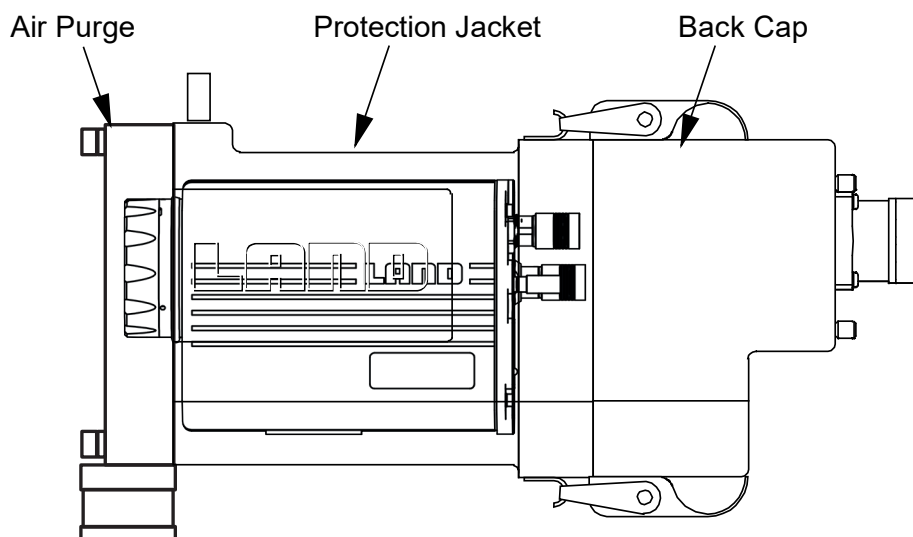

Fig. 1-2 NIR-656/NIR-2K Thermal Imaging Camera with Air Purge, Protection Jacket and Back Cap

1.1 About the NIR-656 / NIR-2K Thermal Imager

The LAND NIR-656 / NIR-2K thermal imager is an accurate, focusable, thermal imager working in near infrared range designed for use in conjunction with *IMAGEPro* or *IMAGEViewer* image processing software.

The thermal imager features include:

- Focusable optical system with range from under 300 mm to infinity
- Accurate measurement of target temperature

1.2 Unpacking the Thermal Imager

The package containing the camera will contain the following items:

- NIR-656 / NIR-2K Camera (fitted with protection cap on the lens).

It is recommended that the front window protection cap is kept attached until the camera is installed.

1.3 Nomenclature

The thermal imager detail label is on the rear face of the thermometer.

The instrument type nomenclature is explained below.

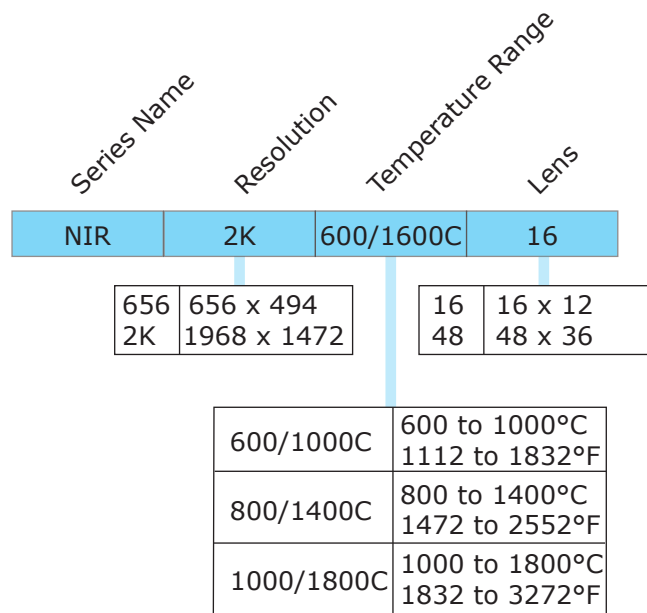

Make a note of your thermometers instrument type and Serial Number in the space provided below.

Instrument type:

Serial Number:

2

SPECIFICATIONS

2.1 Imager Performance

	NIR-656	NIR-2K
Measurement Range	600 to 1600°C / 1112 to 1832°F 800 to 1400°C / 1472 to 2552°F 1000 to 1800°C / 1832 to 3272°F	
Pixel Resolution	656 x 492	984 x 738 1968 x 1476
Spectral Response	1 µm	
Frame Rate	30 fps	30 fps (984 x 738) 15 fps (1968 x 1476)
Detector	FPA - Semiconductor	
Optic FOV (Focal Length)	48° x 36° 16° x 12° See Field of View Diagram (Fig. 2-1).	
Optic (IFOV)	1.28 mrad (48°)/0.43 mrad (16°)	984 x 738: 0.85 mrad (48°)/0.28 mrad (16°) 1968 x 1476: 0.43 mrad (48°)/0.14 mrad (16°)
Focus Range	0.3m to infinity (manual focus)	
Protection Window	Glass (low thermal expansion)	
Accuracy	< 0.5% K of reading (600 to 1000°C, 800 to 1400°C) or < 1% K of reading (1000 to 1800°C) < 0.5% K of reading (1112 to 1832°F, 1472 to 2552°F) or < 1% K of reading (1832 to 3272°F)	
Repeatability	1K	

2.2 Mechanical & Environmental

Dimensions	81 x 114 x 215mm / 3.2 x 4.5 x 8.5in
Weight	Approx. 1.5kg / 3.3lb
Operating Temperature	0 to 50°C/ 32 to 132°F non-condensing (0 to 90% humidity)
Storage Temperature	-20 to 80°C/ -4 to 176°F
Environmental Rating	IP65 / NEMA 4
Vibration	Vibration 3g in all axes 10-30Hz EMC to EN61326-1 industrial
Mountings	2 x 1/4in UNC mounting holes spaced 25mm apart

2.3 Electrical

Connections	2 Pin DC Power (Lemo) / Gbit-Ethernet (RJ45)
Interfacing	Gbit-Ethernet
Power Rating	24V DC, 3W
Signal LED (Status LED)	Power (ON, green) / Camera Temperature/Ambient (OK, green)

2.4 Image Processing

Software	IMAGEPro & IMAGEViewer Advanced image processing and control software
Workstation	PC-Workstation (optional)
Interfacing	Open Data Interface, Modbus TCP, Moxa I/O Unit

2.5 Standard Accessories

Accessories (optional)	Power supply, cables, water cooled/purged enclosure, software, workstation
------------------------	--

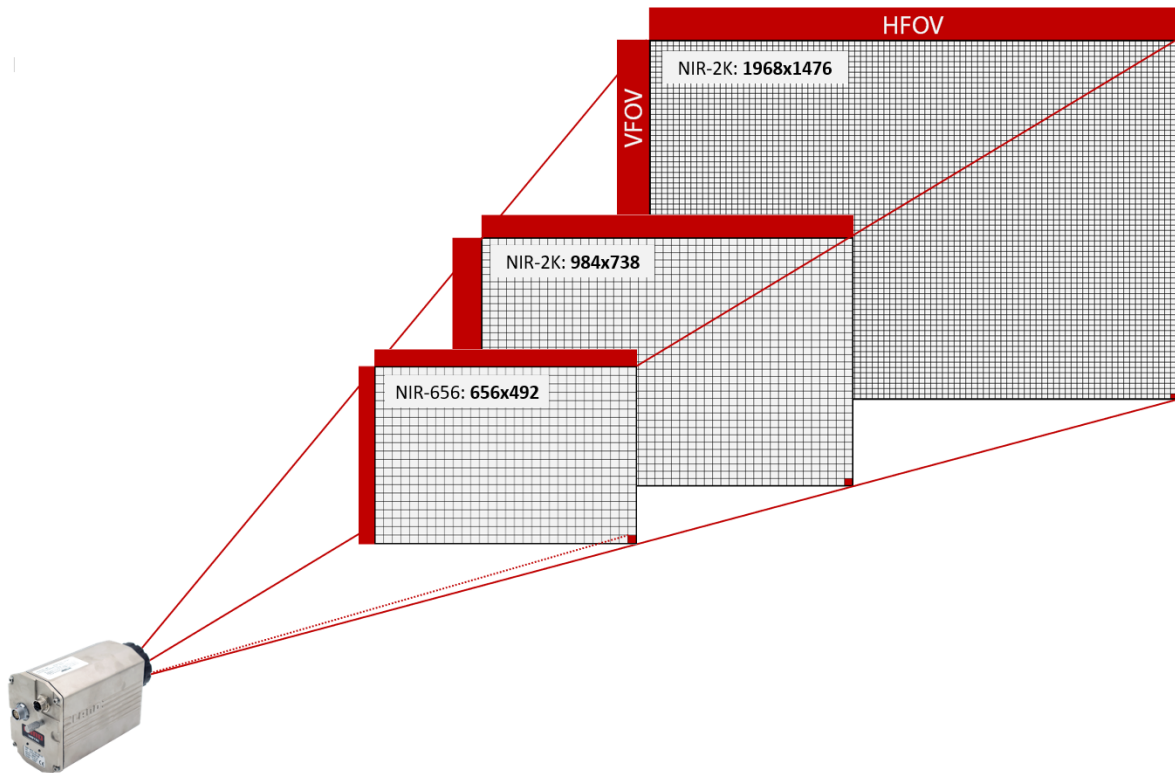

Optic	Distance	1 m			5 m			10 m			15 m			20 m		
		Hres x Vres	Width	Height	IFOV	Width	Height	IFOV	Width	Height	IFOV	Width	Height	IFOV	Width	Height
48° x 36°	656 x 492	0.89 m	0.65 m	1.36 mm	4.4 m	3.2 m	6.7 mm	8.9 m	6.4 m	13.6 mm	13.3 m	9.7 m	20.3 mm	17.8 m	12.9 m	27.1 mm
	984 x 738			0.9 mm			4.5 mm			9.0 mm			13.5 mm			18.1 mm
	1968 x 1476			0.45 mm			2.2 mm			4.5 mm			6.8 mm			9.0 mm
16° x 12°	656 x 492	0.28 m	0.21 m	0.43 mm	1.4 m	1.1 m	2.1 mm	2.8 m	2.1 m	4.3 mm	4.2 m	3.1 m	6.4 mm	5.6 m	4.2 m	8.5 mm
	984 x 738			0.29 mm			1.4 mm			2.8 mm			4.3 mm			5.7 mm
	1968 x 1476			0.14 mm			0.7 mm			1.4 mm			2.1 mm			2.8 mm

Fig. 2-1 NIR-656/NIR-2K Field of View Diagram

3

INSTALLING THE THERMAL IMAGER

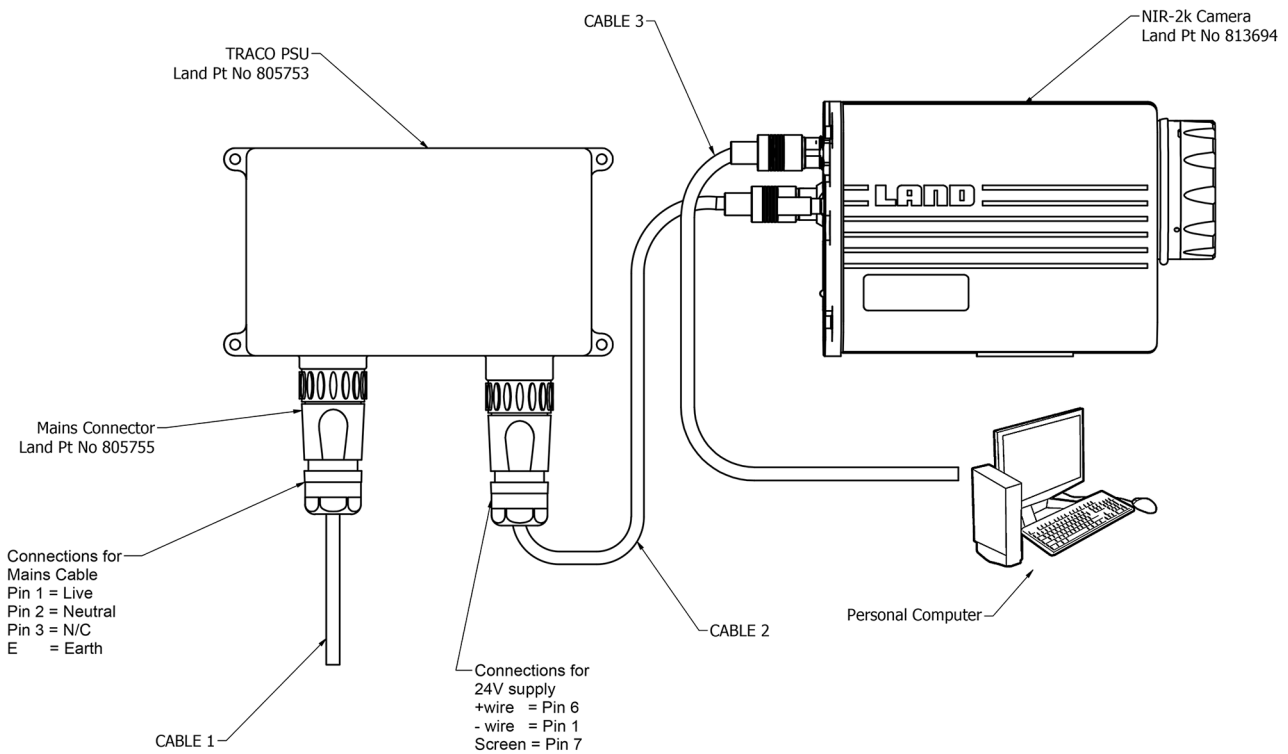

PARTS LIST		
Part No	Description	Quantity
813694	NIR 2K Camera	1
805753	TRACO Power Supply Unit	1
805755	Mains Connector	2
N/A	Personal Computer	1

Cables				
Cable No	Supplied By	Land Pt No	Function	Cable Detail
1	Customer	N/A	Mains Power Input	3 Way Mains Cable
2	Land	814611	24V from PSU to Camera	NIR 2K Camera to Traco PSUCable 5m
		814612		NIR 2K Camera to Traco PSU Cable 20m
		814613		NIR 2K Camera to Traco PSU Cable 50m
3	Land	809294	Ethernet Cable from Camera to PC	M12 to RJ45 Cat6 8 Way 5m
		814616		M12 to RJ45 CAT6 Cable -30C to 70C - 20m
		814617		M12 to RJ45 CAT6 Cable -30C to 70C - 50m

Fig. 3-1 Installation Drawing - NIR-656 / NIR-2K with TRACO Power Supply

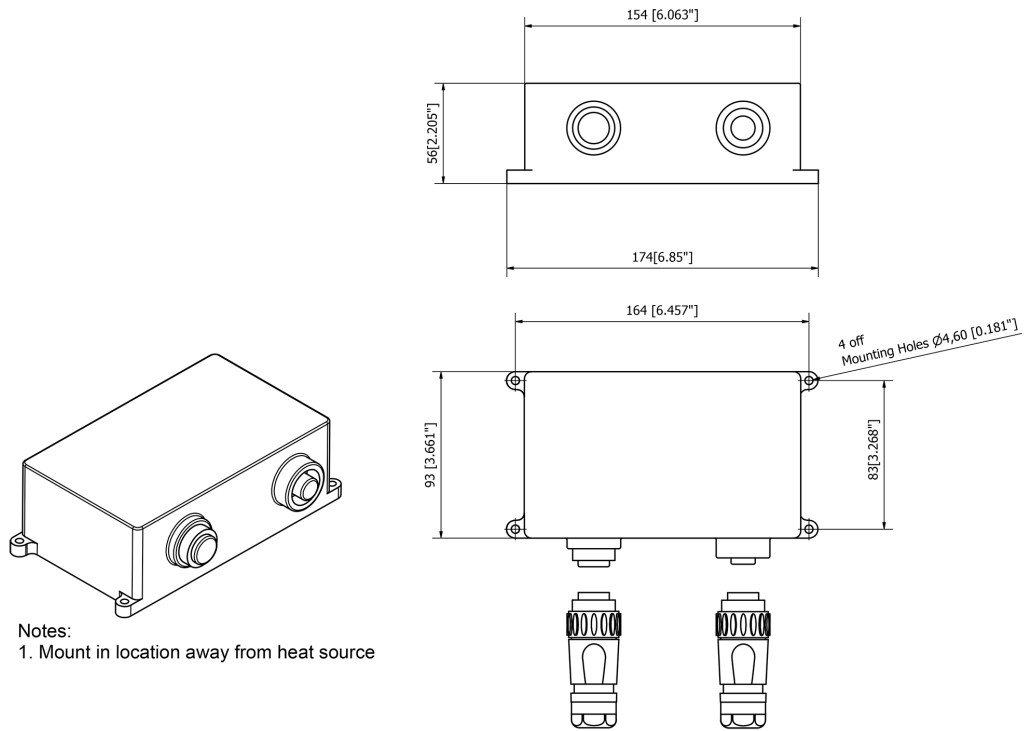

Notes:
1. Mount in location away from heat source

Fig. 3-2 TRACO Power Supply dimensions

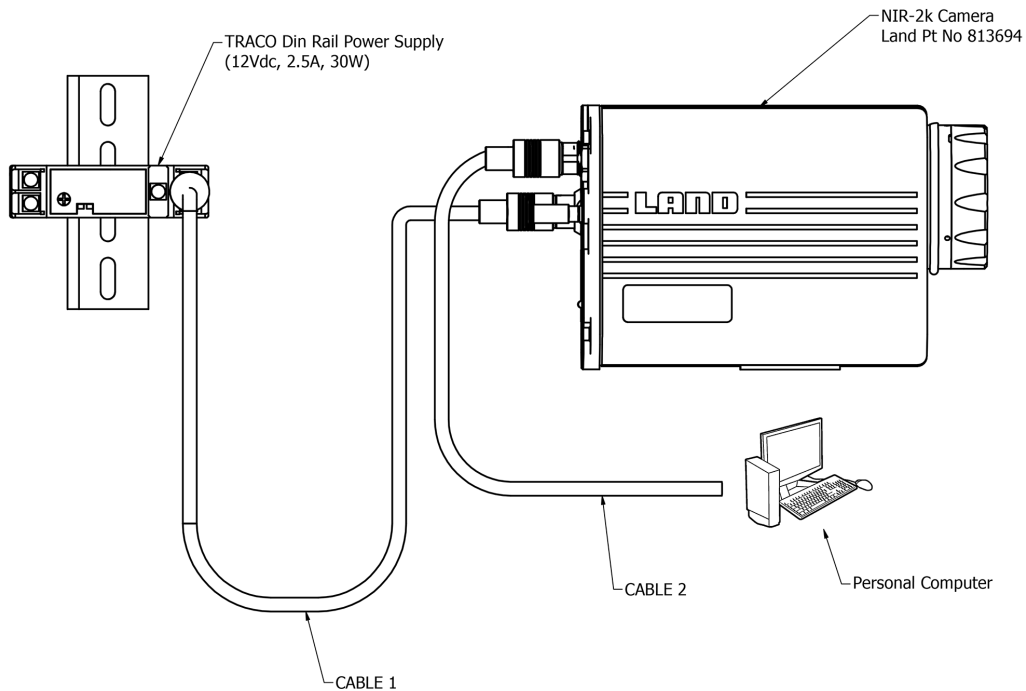

PARTS LIST		
Part No	Description	Quantity
813694	NIR 2K Camera	1
807561	TRACO DIN Rail Power Supply (12Vdc, 2.5A, 30W)	1
N/A	Personal Computer	1

Cables				
Cable No	Supplied By	Land Pt No	Function	Cable Detail
1	Land	814614	12V from Din-Rail PSU to Camera	NIR 2K Camera to DIN Rail PSU Cable 20m
		814615		NIR 2K Camera to DIN PSU Cable 50m
2	Land	814616	Ethernet Cable from Camera to PC	M12 to RJ45 CAT6 Cable -30C to 70C - 20m
		814617		M12 to RJ45 CAT6 Cable -30C to 70C - 50m

Fig. 3-3 Installation Drawing - NIR-656/NIR-2K with TRACO DIN Rail-Mounted Power Supply

If the thermal imager is to be used in conjunction with a protection jacket and air purge, refer to the installation guides provided with those accessories.

If the thermal imager is to be installed in a location where the ambient temperature is within the ranges specified for the thermal imager, and no air purging is required to keep the lens clean, the thermal imager can be mounted using the two tapped holes on the mounting pad. Either hole can be used for direct tripod mounting.

A swivel ball mounting (S4 - B) is available from Land infrared. This mounting accessory enables you to easily adjust the thermal imager's line of sight.

3.1 Fields of view

See also Field of View Diagram (Fig. 2-1).

Two fields of view are available:

- 16° x 12°
- 48° x 36°

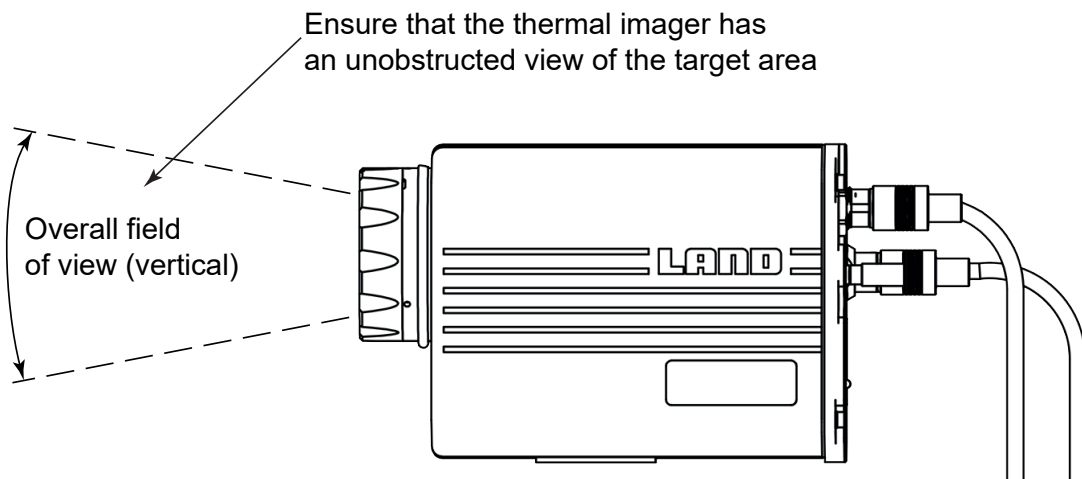

Fig. 3-4 Thermal imager field of view

3.2 Thermal Imager installation dimensions

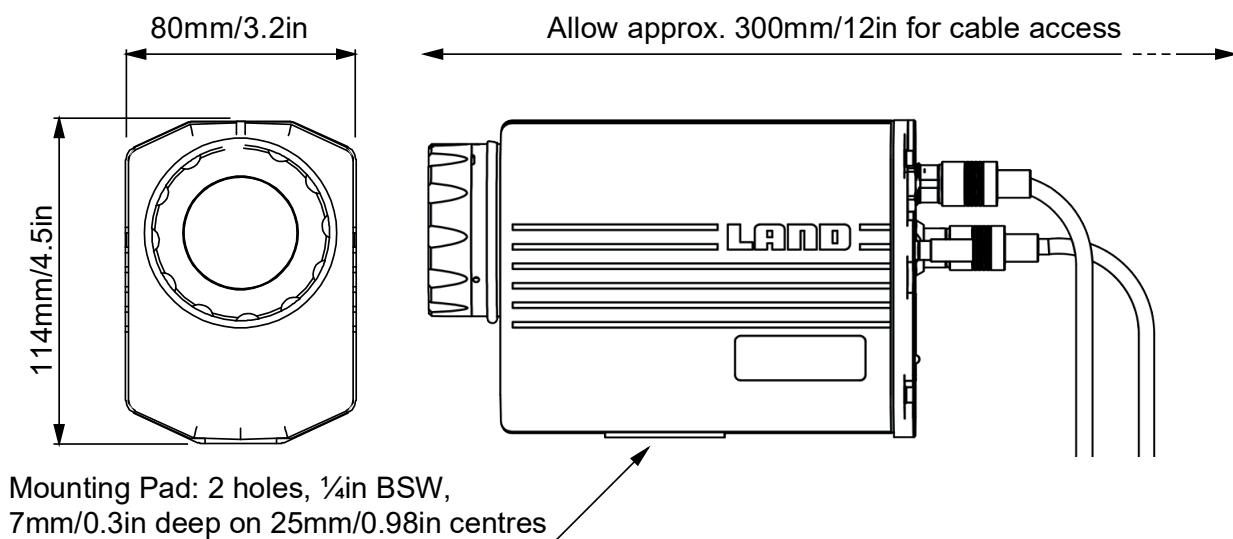

Fig. 3-5 Thermal Imager installation dimensions

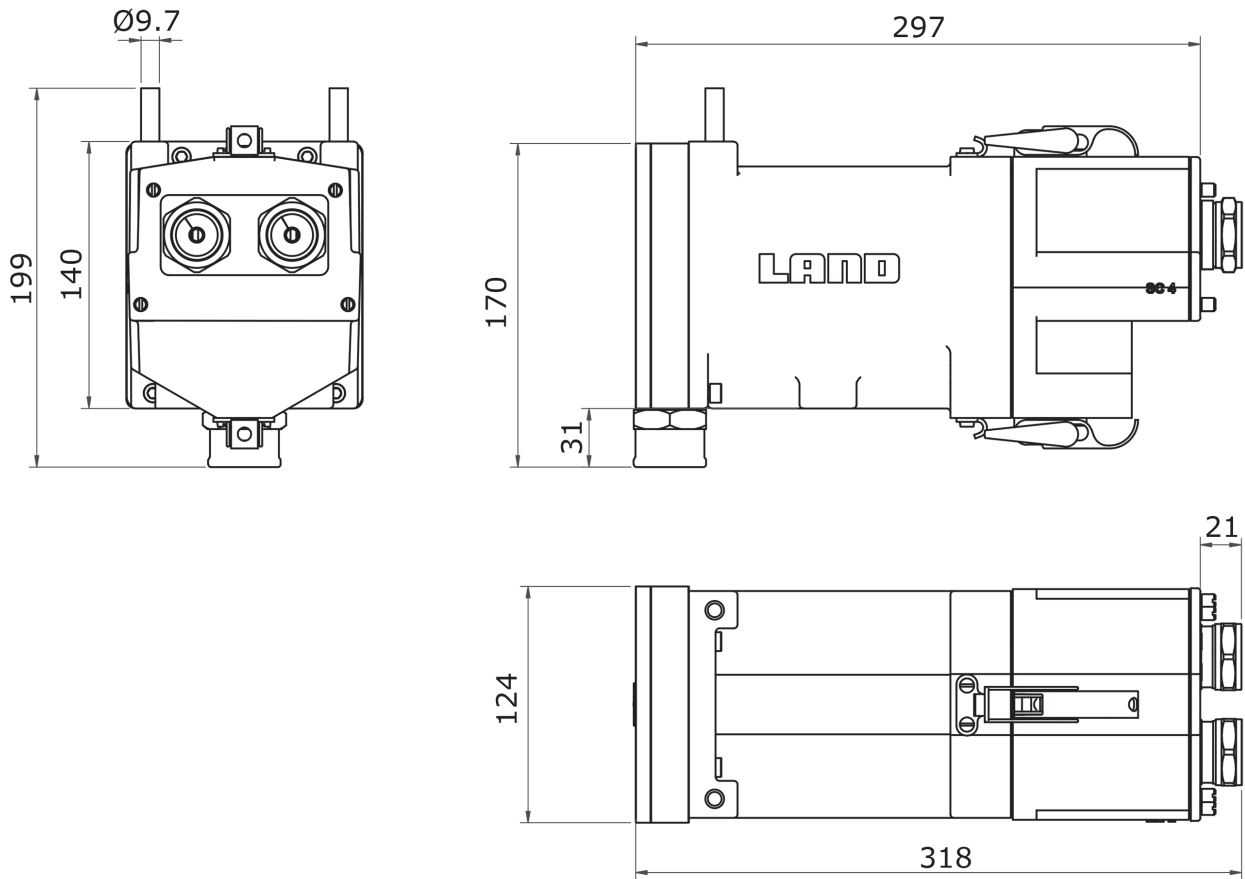

Fig. 3-6 Protection Jacket and Back Cap installation dimensions

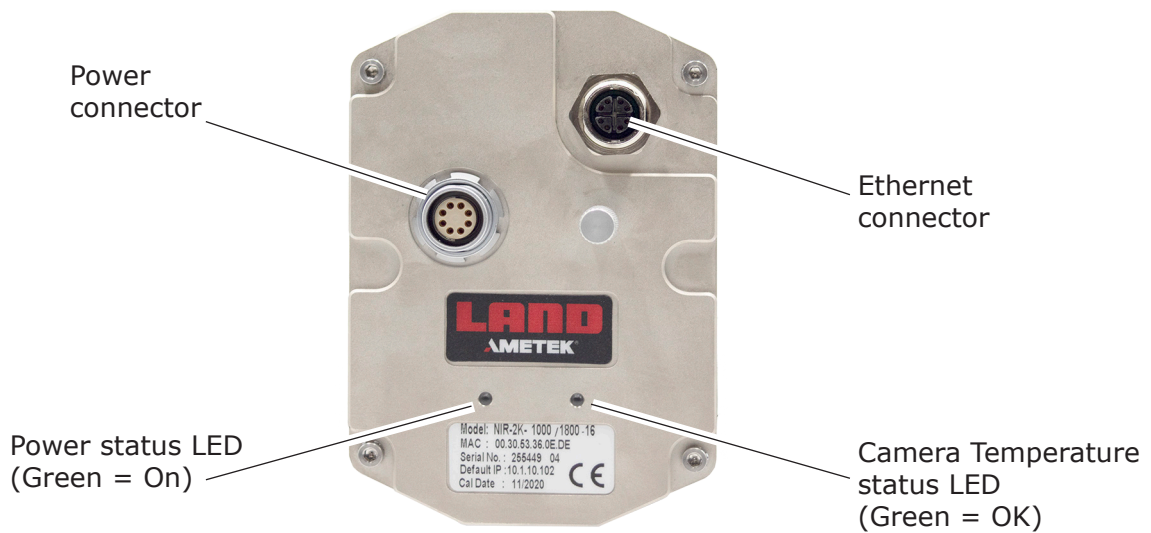

Fig. 3-4 Location of connection sockets and LEDs on rear face of thermal imager

4

ELECTRICAL CONNECTIONS

There is a choice of Power Supply Units available:

- Thermal Imaging PSU Module (UL Approved) - Part N° 813478
- Process Imaging Power Supply (TRACO) - Part N° 805753
- Process Imaging Power Supply - DIN Rail-mounted (TRACO) - Part N° 404.156
- Customer's own +24V Power Supply

Depending on your choice of Power Supply, refer to the manufacturer's user documentation supplied with your Unit.

The electrical connections for the thermal imager power supply are made via the Digital data over 1 GBit Ethernet (M12, 8 pin) and the 8 pin Power socket on the rear of the thermal imager. See Fig. 3-4.

Electrical connection to the thermometer must be made via the pre-wired plug and cable. The cable is screened. The screen is connected to the connector shell, and thus to the camera body of the NIR-656/NIR-2K. The screen must also be grounded at the power supply. There are cable options available for both length and termination at the power supply. For details, see Section 6 'Spares & Accessories'.

To connect the cable:

- 1) Refer to Fig. 3-4. Align the red marker near the lugs of the pre-wired plug with the red marker above the keyway in the socket on the thermal imager.
- 2) Push the plug into the socket.

To disconnect the cable:

- 1) Grip the locking sleeve section of the plug.
- 2) Pull the plug outwards to release the locking mechanism and disconnect the cable.

4.1 Connecting the mains input to the TRACO Power Supply Unit



Fig. 4-1

The TRACO Power Supply Unit is supplied with a 3-pin AC input connector (Fig. 4-1). You will need to disassemble this connector to install the cable.

- 1) Unscrew the cover from the mains **Input** on the Power Supply Unit.



Fig. 4-2

- 2) The easiest way to disassemble the 3-pin AC input connector is to first screw the connector assembly onto the input socket (Fig. 4-2).



Fig. 4-3

- 3) Grip the rear section of the input connector and unscrew it from the Power Supply Unit (Fig. 4-3).



Fig. 4-4

The connection terminals inside the input connector will now be revealed (Fig. 4-4).

- 4) Unscrew the connector front section from the Power Supply Unit and disassemble the remaining parts of the connector.
- 5) Slide the rear locking ring, gasket and shell body over the mains input cable.

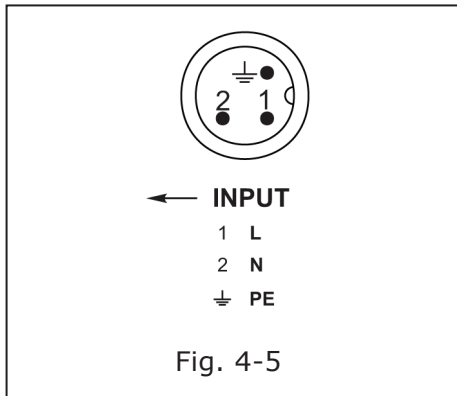

- 6) Strip back the mains cable wires to the appropriate lengths and connect them to the **Input** connector terminals (Fig. 4-5) as per the wiring schedule below:

Pin 1 = Live
Pin 2 = Neutral
Pin 3 = N/C
E = Earth

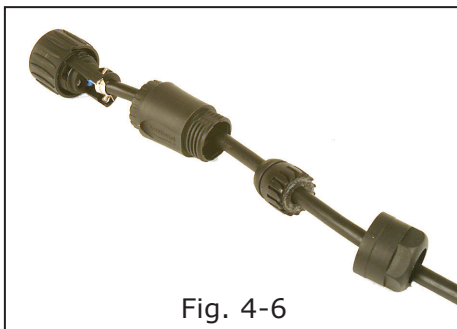

- 7) The mains input cable connector is now ready for re-assembly and connection to the Power Supply Unit (Fig. 4-6). Reassemble the mains input connector.



- 8) Attach the mains cable to the Input connector of the Power Supply Unit (Fig. 4-7). You can now connect the TRACO Power Supply Unit to the NIR-656/NIR-2K Thermal Imager camera via the pre-wired power cable assemblies.

4.2 Using an alternative Power Supply Unit

If you do not have a TRACO Power Supply Unit, you can use a 24V DC supply to power the NIR-656/NIR-2K Thermal Imager.

You will need to connect the camera to the power supply via a cable, available from AMETEK Land:

Two lengths of cable are available:

Length: 20m/66ft, Part N° 814614

Length: 50m/164ft, Part N° 814615

Minimum bend radius: 50mm/2in

Recommended mounting method: Cable fixings/Conduit (Insulate as necessary)

IP Rating: IP65

Cable connections:

Black - connect to + 24 Volts

White - connect to 0 Volts

4.3 Ethernet Communications (Gig-E) Data Output

The output from the imager to the PC uses a Gig-E Ethernet link: the cable standard is Cat 6 or higher. The cable must be screened and the screen terminated at both ends.

The maximum Gig-E cable length is 80 m.

Connect the appropriate Gig-E lead between the 8-pin M12 Ethernet connector on the rear of the imager body to that on the PC.

For installations where the imager is mounted within a protection jacket and end cap, a fully sealed connector is not required.

For all other installations, an IP65 seal is required at the connector on the rear of the imager.

For details of the cable options available, refer to Section 6 'Spares & Accessories'.

5

USING THE THERMAL IMAGER

The NIR-656/NIR-2K Thermal Imaging Camera is designed to be used with software available for download from the AMETEK Land website.

- IMAGEPro is available on a 30-day free trial
- IMAGEViewer is free

Ensure that the imager is powered up and the Ethernet communications cable is installed correctly between the imager and the PC.

Run the downloaded software. It may take up to one minute for the software to detect and connect to the imager.

IMAGEPro and IMAGEViewer will then automatically display an image of the scene within the camera's field of view.

5.1 Focusing the thermal imager onto the target

If an individual target is to be measured, focus the camera onto the object by gripping and rotating the front window retaining ring.

Rotate the ring clockwise to focus on more distant objects: rotate anticlockwise to focus on nearer objects.

Note that the overall degree of rotation varies with lens type, but is always between a quarter and a half-turn.

If no particular target object is to be measured, then rotate the focus ring to give the best overall image resolution across the whole scene.

Make any necessary adjustments to the imager's mounting to ensure the best possible view of the required scene.

6

SPARES & ACCESSORIES

The following accessories are available for all cameras in the NIR-656/NIR-2K range.

Description	Land Part Number
Water Cooled Housing	
NIR-656/NIR-2K Water Cooled Housing	091-560
Power Cables for Thermal Imaging Power Supply Unit	
20m Imager to Power Cable with 2x Conn, Standard Temperature	803971
25m Imager to Power Cable with 2x Conn, HIGH Temperature	810795
50m Imager to Power Cable with 2x Conn, HIGH Temperature	810890
Power Cables for Process Imaging PSU (TRACO)	
20m Imager to Power Cable with 2x Conn, Standard Temperature	814611
25m Imager to Power Cable with 2x Conn, Standard Temperature	814612
50m Imager to Power Cable with 2x Conn, Standard Temperature	814613
Power Cables for DIN Rail PSU (TRACO) or customer's own Power Supply Unit	
20m Imager to Power Cable with 1x Conn, Standard Temperature	814614
50m Imager to Power Cable with 1x Conn, Standard Temperature	814615
Communications Cables	
M12-M12 CAT6 8-Way Ethernet Cable - High Temperature (Max 160 °C/320 °F) Length: 25m/82ft	814616
M12-M12 CAT6 8-Way Ethernet Cable - High Temperature (Max 160 °C/320 °F) Length: 50m/164ft	814617
Power Supplies	
Thermal Imaging Power Supply (UL Approved)	813478
Process Imaging Power Supply (TRACO)	805753
Process Imaging Power Supply - DIN Rail-mounted (TRACO)	404.156

NIR-656 / NIR-2K

HIGH RESOLUTION THERMAL IMAGING

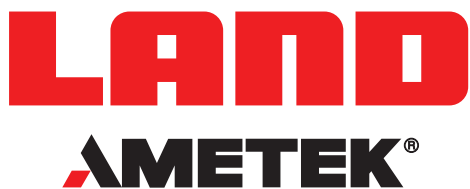

CONTACT US



www.ametek-land.com



land.enquiry@ametek.com



AMETEK Land's AMECare Performance Services ensure peak performance and maximum return on investment over the life of your equipment.

We deliver this by:

- Proactively maintaining your equipment to maximize availability.
- Optimizing solutions to meet your unique applications.
- Enhancing user skills by providing access to product and application experts.

AMETEK Land's global service network provides unparalleled after-sales services to ensure you get the best performance and value from your AMETEK Land products. Our dedicated service centre teams and on-site engineers are trained to deliver the highest standard of commissioning, maintenance and after-sales support.

Our worldwide network of Service Centres includes:

UNITED KINGDOM | USA | UAE | ITALY | INDIA | GERMANY | CHINA

WWW.AMETEK-LAND.COM/SERVICES

For a full list of international offices, please visit our website www.ametek-land.com

Copyright © 2021 LAND Instruments International.

Continuous product development may make it necessary to change these details without notice.

NIR-656 / NIR-2K Camera Installation Guide, Issue 1, 01 February 2021